

DOI: <http://dx.doi.org/10.21123/bsj.2022.19.1.0141>

Flow Injection Analysis with Turbidity Detection for the Quantitative Determination of Mebeverine Hydrochloride in Pharmaceutical Formulations

Nagham S. Turkey

Jalal N. Jeber *

Department of Chemistry, College of Science, University of Baghdad, Baghdad, Iraq

*Corresponding author: jalal.n@sc.uobaghdad.edu.iq, nagamturkey@yahoo.com

*ORCID ID: <https://orcid.org/0000-0001-6168-3309>, <https://orcid.org/0000-0002-6562-0636>

Received 27/8/2020, Accepted 26/10/2020, Published Online First 20/7/2021, Published 1/2/2022



This work is licensed under a [Creative Commons Attribution 4.0 International License](https://creativecommons.org/licenses/by/4.0/).

Abstract:

The main objective of this paper is to develop and validate flow injection method, a precise, accurate, simple, economic, low cost and specific turbidimetric method for the quantitative determination of mebeverine hydrochloride (MbH) in pharmaceutical preparations. A homemade NAG Dual & Solo (0-180°) analyser which contains two identical detections units (cell 1 and 2) was applied for turbidity measurements. The developed method was optimized for different chemical and physical parameters such as perception reagent concentrations, aqueous salts solutions, flow rate, the intensity of the sources light, sample volume, mixing coil and purge time. The correlation coefficients (r) of the developed method were 0.9980 and 0.9986 for cell 1 and 2 respectively and showed the linearity of response against concentration over the range of 1.0 to 6.5 and 0.7-6.5mmol/L for cell 1 & 2 respectively. The limit of detections (LOD) for cell 1 and cell 2 were 0.28 and 0.21 mmol/L respectively. The intra-day and inter-day precision for two serial estimations of 3.5 and 5.5 mmol/L of MBH exhibited a relative standard deviation of 0.46%, 0.28%, 0.23%, 0.26% and 0.39%, 0.79%, 0.14%, 0.05% for cell 1 & 2 respectively. The accuracy of the developed method has expressed a recovery percentage (Rec %) and error % which was between 99.22 to 101.13 and 99.39 to 101.17 for cell 1 and cell 2 respectively. The ICH guidelines were followed for method validation. The developed method was successfully applied for the determination of MbH in pure and pharmaceutical preparations and the method can be conveniently used for routine analysis in laboratory as a quality control method since the method permits quantitatively determination of 60 samples/h.

Key words: Flow injection, Mebeverine hydrochloride (MbH), Pharmaceutical preparations, Quality control, Turbidity.

Introduction:

Mebeverine hydrochloride (MbH) is a musculotropic antispasmodic drug without any side effects on the normal gut motility. It is chemically known as 4-[Ethyl-[1-(4-methoxyphenyl) propan-2-yl] amino] butyl 3,4- dimethoxybenzoate hydrochloride (Fig. 1). Irritable bowel syndrome (IBS) and gastrointestinal spasm are mainly treated by Mebeverine hydrochloride¹⁻³. Its action on the smooth muscle of the colon is to reveal spasm with normal gut motility⁴. Therefore, it represents the most prescribed drug which is currently available for treating gastrointestinal spasm and irritable bowel syndrome⁵⁻⁷. In 2000, the MbH was

officially registered in the British Pharmacopoeia⁸. In the literature, several analytical procedures have been described for the quantitative determination of MbH in the pharmaceutical formulations, bulk and biological fluids. Among the described methods are electrochemical⁹, spectrofluorometric¹⁰⁻¹¹, spectrophotometric¹²⁻¹⁹, chromatographic method^{20, 21}, MIP²², HPLC²³⁻²⁹, potentiometric^{30, 31}, online micellar chromatography³², HPTLC³³, super critical fluid GC-MS³⁴, and reversed-phase LC-GC³⁵. Mainly the chromatographic methods in spite of their high sensitivity and accuracy but are time-consuming, expensive and require special

laboratory training. The ion-selective methods have found their way in the applications of the drug analysis fields, being selective, sensitive and low cost, and can be applied over a wide range of experimental conditions³⁶⁻³⁸. Recently, many sensitive ion-carriers and highly selective which were synthesized and designed as sensors of molecules have been reported³⁹. However, there has not been improvement or development in the selectivity of mebeverine hydrochloride sensing and still suffering from the interferences. A flow injection technique based on turbidity principle method is a powerful method and has been used for determining lots of pharmaceutically active ingredients in pharmaceutical formulations^{40, 41} Till to date and based on the scientific literature, analysis of the MbH in pure and pharmaceutical preparations using flow injection technique based on turbidity detection has not been reported. The proposed method could selectively determine MbH in the commercial dosage forms without prior separation. Thus, it was important to develop a new method for the determination of MbH without any derivatization in the chemical composition of pharmaceutical preparations. The present work describes a newly turbidimetric flow injection method to establish an easy, rapid, sensitive, economic and accurate method for the determination of MbH in pharmaceutical preparations.

Material and Methods:

Material: All Standards of Sodium nitrite, Potassium nitrate, Sodium chloride, ammonium chloride, Potassium bromide were purchased from Sigma Aldrich, all with purity higher than 98%. All the solvents that were used in the current study were HPLC purity. For the preparation of aqueous solutions, double-distilled (deionized) water was used. Reference standards material of pure MbH was a gift from the State Company of Drug Industries and Medical Appliances (Samara, IRAQ-SDI). While the MbH tablets were procured from the local market under the brand name ((Colofac® (Abbott, France), Colospasmin® (EIPICO, Egypt) and Duspalina® (Asia, Syria)) which comprise (135 mg of MbH).

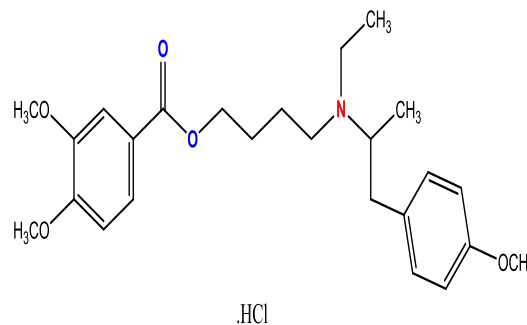

Figure 1. The chemical structure of Mebeverine hydrochloride (MbH)

Preparation of stock and standard solutions: 5.285 g of MbH was dissolved in 250 ml of double-distilled water in order to prepare the stock solution of MbH (50 mmol/L). The stock solution was then stored in an amber bottle for further experiments. The standards solutions of MbH were prepared by dilution appropriate volumes of stock solution with double distilled water to obtain standard solutions ranging from 0.25-25 mmol/L. During the proposed analytical procedure of the MbH, the stability of the MbH was monitored using UV spectrophotometry and the results showed there is no decomposition in the MbH during the proposed method.

Preparation of samples (Tablets): Three different commercial companies of 135 mg of MbH (Colofac® (Abbott, France), Colospasmin® (EIPICO, Egypt) and Duspalina® (Asia, Syria) were investigated in the current study. The stock solution of MbH of each company was prepared by following the same procedure. The preparation procedure of the stock solution (100 mmol/L) is conducted by taking 20 tablets of 135 mg of MbH from each commercial drug and then it was precisely weighted and finely powdered. An accurate amount of the powdered tablet contents equivalent to 135 mg of the MbH (active ingredient) was transferred into a 100 mL volumetric flask. The powdered tablet was completely dissolved in distilled water using a mechanical stirrer. The stock solution of the tablet was filtered off and transferred into 50 ml volumetric flask.

Apparatus: In order to determine the concentration of MbH in tablets using phosphomolybdic acid as a precipitation reagent, a new manifold flow injection system was used as shown in Fig 2. This system contains a peristaltic pump, Y-junction point, injection valve (6 ports) and two lines, the line no 1 is for the carrier streamline and line 2 for the precipitating reagent. A NAG Dual & Solo (0-180°)

analyser has been used as a detection unit in this system. Teflon tubes (0.5 mm diameter) were used to connect the flow system parts with each other. The manifold system contains A NAG Dual & Solo (0-180°) analyser (detection unit) which contains two identical twin cells i.e., cell no. 1 and cell no. 2, each one of them has 100 mm length, and in between of them there is a 20 mm without any detection. The obtained profiles of the S/N against the time from the A NAG Dual & Solo (0-180°) analyser are shown in a chart (Fig 3). The light source in the analyser unit is white snow led, each measuring cell contains 10 white snow LED (WSLED) as an irradiation source (blue-violet 42.4%, Green 56.73% and 1.15% Red). Each one of the WSLED irradiates a circle spot of 3mm diameter for the flow cell O_p 4mm (Outer diameter of the flow cell) and I_p 2mm (Internal diameter of the flow cell) of the active total distance of the cell. Each cell unit is supplied by 3-solar cells to cover up the inlet distance of 100mm (solar cell dimension 37.8mm (L)x10mm (W)x1mm (thickness). Identical twins' solar cells are used with minimum 2.5VDC at ambient light. The analyser unit has been checked and validated based on Central Organization for standardization and quality control (Patent No: N5490, International classification No (G01N33/0013, 6)). For the reference's methods (UV and turbidity), a UV-Vis spectrophotometer type double-beam (Shimadzu, model 1601) and portable turbidity meter instrument (Hanna, model LP 2000) with quartz cell size 10 ml have been used.

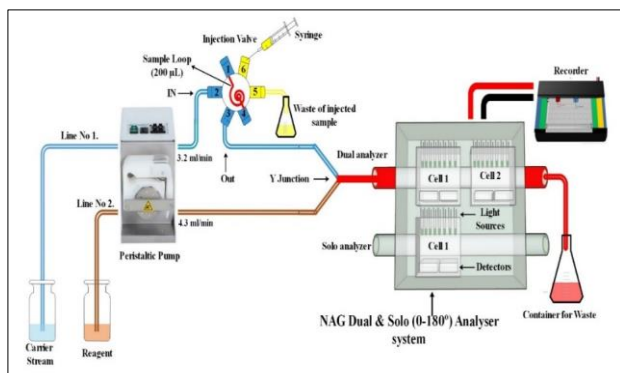

Figure 2. The configuration of the manifold for the flow injection system

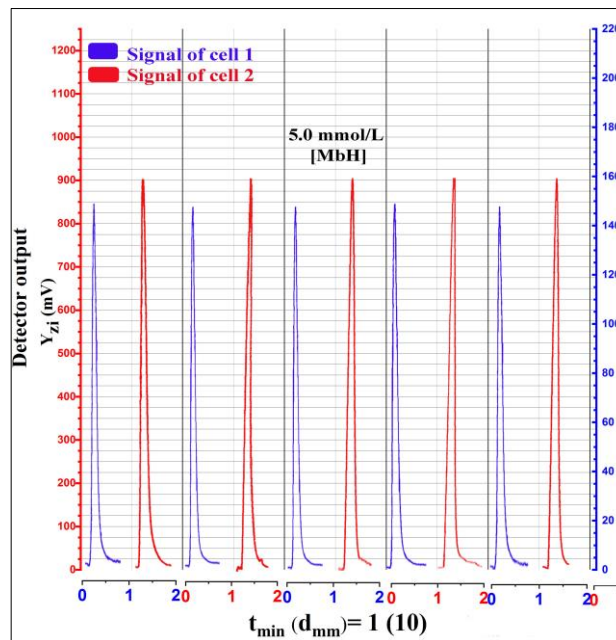

Figure 3. The signals profiles of the S/N against the time obtained for MbH at 5.0 mmol/L

Methods

The methodology of the proposed method: The proposed method is based on the forming of an ion association complex by the reaction between the precipitation reagent (Phosphomolybdic acid) and the drug. The reaction occurs at Y-junction point, a certain volume of the drug is injected through the injection valve and transferred by the carrier streamline to the Y-junction point to mix with reagent line at that point. After that, the formed complex is transferred into the analyser unit by both of the carrier stream and reagent lines. The proposed mechanism of the reaction between the MbH and the PMA is shown in Fig 4. The analyser device composites of two cells, each one of them works separately and acts as a detector. Therefore, two signals will be obtained eventually, one of them belongs to the cell number one and the other for cell 2. These signals will be shown on the chart and are treated mathematically. After obtaining the treated data, the concentration of MbH can be determined.

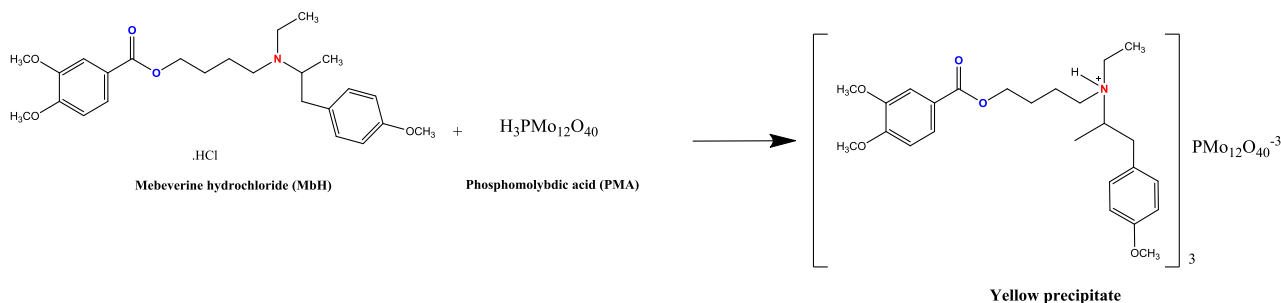

Figure 4. The proposed mechanism of the reaction

Optimizing the chemicals and physical parameters: Chemical variables:

Phosphomolybdic acid (PMA) concentration:

The stock solution of phosphomolybdic acid (Precipitation reagent) was prepared by dissolving PMA in distilled water to obtain the concentration of 50 mmol/L. A series of solutions was prepared by dilution of stock solution with distilled water to obtain the concentrations ranging from (3-20 mmol/L). The experimental conditions of the measurements were: MbH 50 mmol/L, sample volume 200 μ L, light intensity (I=1, 4 for cell 1 and cell 2 respectively), open valve mode and flow rate

of 3.2 ml.min⁻¹ for carrier stream (Distill water) and 4.3 ml.min⁻¹ flow rate for reagent. The obtained results have shown that there is a gradual increase in the peak height during increasing in the reagent concentration reaching 20 mmol/L of PMA. However, at 17 and 20 mmol/L there is an insignificant increase in the peak height which probably indicates there is no increase in the concentration of precipitation product at these concentrations. Therefore, the 15 mmol/L of PMA reagent was chosen to be the optimum concentration for further experiment as shown in Fig 5.

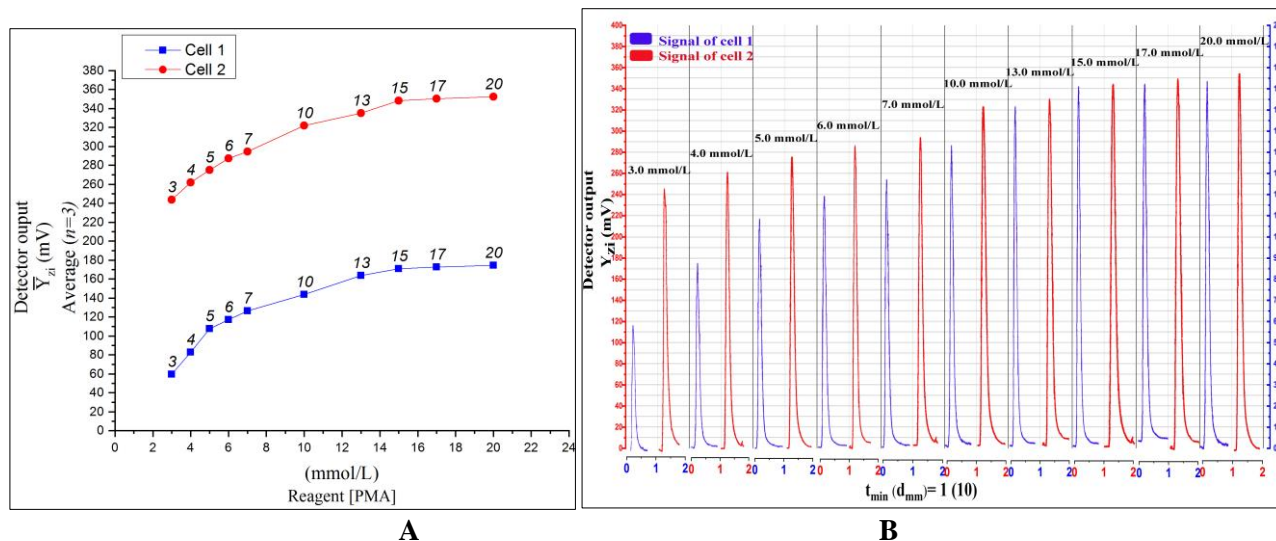

Figure 5. A: represents the effect of PMA Conc. [mmol/L]; B: the real signal obtained from the detector

Effect of aqueous salt solutions: In order to check if they can enhance the S/N energy transducer response, different aqueous salts solutions (H₂O, NH₄Cl, NaCl, KBr, CH₃COONH₄, NaNO₂, KNO₃, HCl, HNO₃ and CH₃COOH) have been prepared at 100 mmol/L and were used instead of the distilled water as a carrier stream. The experimental conditions of the experiment were: the flow rate of

the carrier stream 3.2 ml.min⁻¹, while 4.3 ml.min⁻¹ flow rate for reagent with sample volume 200 μ L, light intensity (I=1, 4 for cell 1 and cell 2 respectively), and open valve mode. It can be observed that there is an increase in sensitivity of response in aqueous medium as carrier stream compared with the use of different salts that it due to decreasing the S/N energy transducer response; this might be attributed to the disperse of precipitate

particulate in the presence of salts. Therefore; aqueous medium was chosen as the optimum medium (carrier stream) (Figs 6 and 7).

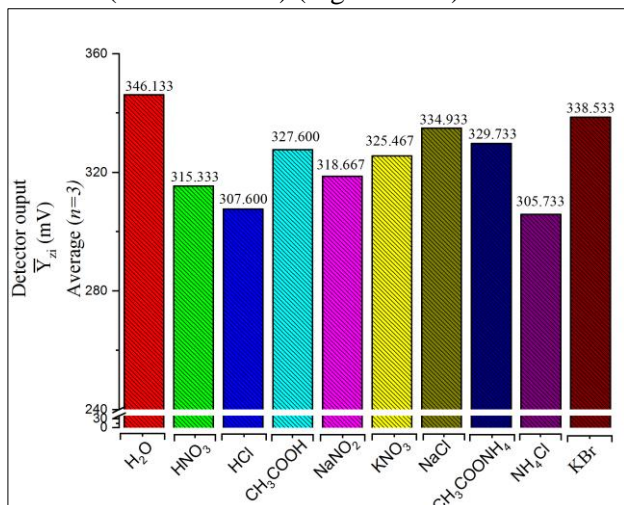

Figure 6. Effect of using different salt on the peak height for cell 1

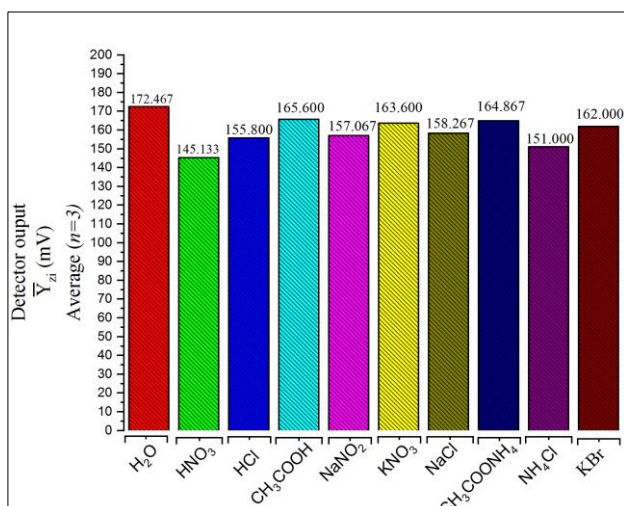

Figure 7. Effect of using different salt on the peak height for cell 2

Physical variables:

The effect of using variables intensities of white snow light emitting diodes (WSLEDs): To investigate the effect of intensity of light source on the S/N profiles, variable intensities of the incident light of cell 1 and 2 were used in A NAG Dual & Solo (0-180°) analyser. The selector switch of light source provides 5 levels of light intensities starting from I= 1 (the lowest level) and end up to the I=5 (the highest level) in addition to the off position for both cells which are individually controlled which means each one of the instrument cells has its own selector switch of the light source. Therefore, at the

following experimental conditions: 50 mmol/L of MbH, 15 mmol/L of PMA, 3.2 & 4.3 ml.min⁻¹ flow rates for carrier stream (distilled water) and reagent respectively with sample volume 200 μL and open valve mode were used in order to investigate the effects of the light intensity on the response profiles. From the obtained results it was observed that, for the cell 1, the favored light intensity was I=1, and this is may be attributed to the nature of the formed precipitate particles which means the well-distributed particles with small size can leave very short spaces between them during passing through the cell 1, therefore, using a low intensity of light source can detect these particles and obtaining a signal instead of using high intensity of the light source which cannot detect these small sizes of particles. On the other hand, cell 2 preferred intensity of light I= 5, and this is can be explained by the same fact, during passing through the cell 1, the particles will start to growing up and suffering from conglomeration and as a result of that, the particle size will be increased. At this point using a low intensity of light source cannot be useful therefore, the light intensity of the light source must be high. Thus, the intensity of light (I=1,) was chosen to be the optimum intensity for further experiment for cell1 and 2 respectively as shown in Fig 8.

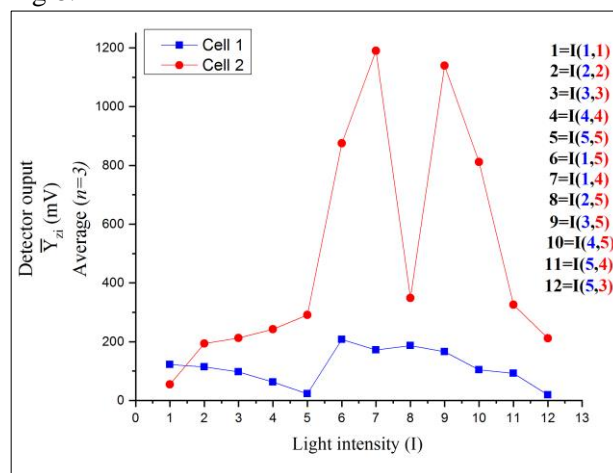

Figure 8. The effect of light intensities

Effect of flow rate: In order to choose the optimum flow rate for both of the carrier stream-line (distilled water) and the reagent line 60 mmol/L (PMA), ranges of flow rates have been applied for the carrier stream which is (0.75-5.3 ml/min) and the reagent line which is (0.82-6.7 ml/min). While the other experimental conditions i.e.; MbH 7 mmol/L, 200μL sample volume, light intensity (I=1, 4 for

cell 1 and cell 2 respectively) and open valve mode are kept constant. The obtained results have shown that at a low flow rate for both of the carrier stream-line and the reagent line there is a gradual increase in S/N profiles for cell 1 & 2 up to (2.80 & 3.30 ml/min) for stream-line and reagent line respectively and the bases of these responses are wide. At a high flow rate (i.e.; more than 2.80 and 3.30 for carrier stream and reagent lines

respectively), the S/N profiles of these flow rates have decreased and became very sharp with the base of these peaks became narrow, but it is not very high due to departure of the precipitate particles from the measuring cells at a short time. Therefore, the flow rates 2.80 & 3.30 ml/min for stream-line and reagent line respectively were chosen to be the optimum flow rates (Fig. 9).

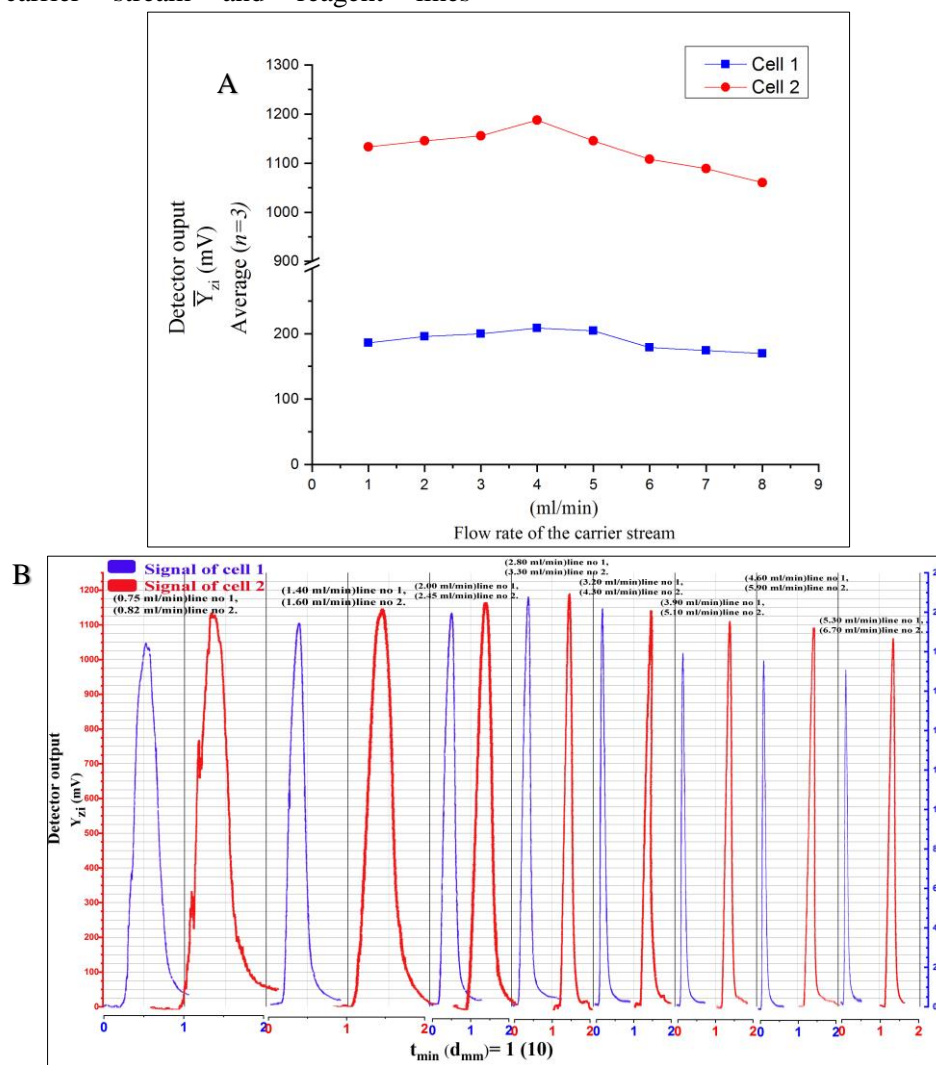

Figure 9. A: represents the effect of flow rates; B: the real signal obtained from the detector

The effect of the sample volume in CFIA: In this experiment, variable of sample volume ranges from (32-300 μL) using Teflon tubes (4.07-38.17 cm) with 0.5 mm as a diameter were used. The results have shown that there is an increase in the peak high during the increase in the sample volume up to

200 μL , at this point, the maxima peak high was recorded as sample volume 200 μL (25.45 cm as a length of sample segment). Therefore, 200 μL has chosen to be the optimum sample volume and use it in further experiments as shown in Fig. 10.

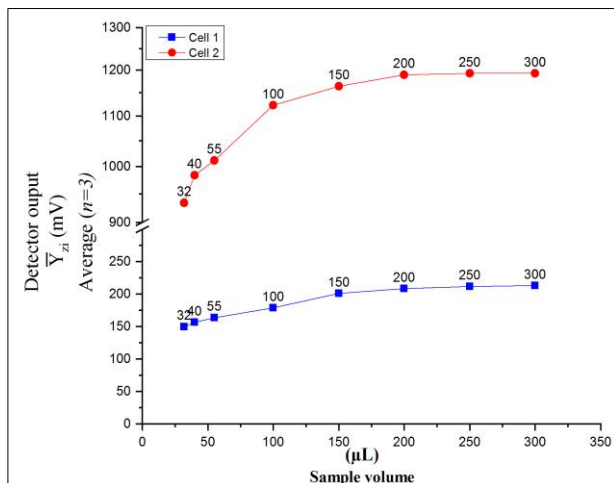

Figure 10. The effect of sample volumes

The effect of mixing coil: In order to check whether the length of the mixing coil has an effect on the formation of the complex, Teflon tubes with different length of 10, 15, and 20 cm were used. Optimization the length of the mixing coil was carried out by 50 mmol/L, flow rate 2.8 ml min⁻¹ and 3.3 2.8 ml min⁻¹ for cell 1 and 2 respectively and sample loop of 200 µL. The results have shown that there is no improvement in the sensitivity of the peak height has recorded in comparison with the system without using the mixing coil which indicates that the reaction between the MbH and the PMA is already complete and the manifold system does not need any mixing coil.

Purge time of the sample segment: The required time for the all sample segment to leave from the injection valve (Purge time) was investigated at periods of times ranging from (3-30 sec and open valve mode). The obtained results have come to match the dilution factor results. The results have shown that 15 sec is the time that the sample segment requires to leave from the injection valve towards the Y-junction. Therefore, from 15- open valve mode considered as the optimum purge time of the sample segment and it can choose any one of those times that fall in that range as shown in Fig. 11.

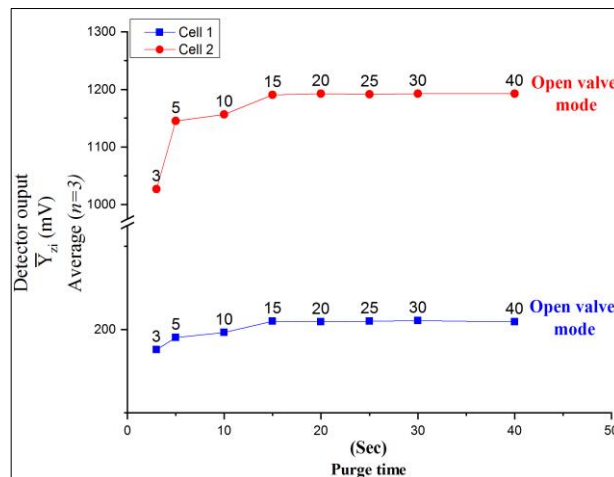

Figure 11. The effect of purge time

Validation parameters of proposed methods: The proposed methods have been validated based on The International Council for Harmonisation of Technical Requirements for Pharmaceuticals for Human Use (ICH guidelines)⁴². Therefore, the developed method was validated for precision, accuracy, specificity, linearity, LOD and specificity.

Calibration curve: It is a general procedure which is used for determining the concentration of a chemical substance in an unknown sample by establishing a set of known concentration and comparing it with the unknown. For the proposed method, the calibration curve was constructed by applying all the optimum chemical and physical parameters which were chosen. After that, a series of MbH concentrations were prepared in the range of 0.1-15 mmol/L. The calibration curve was constructed using the X- value (concentrations of MbH) as independent value and Y-value (attenuation of the incident light produces S/N energy transducer responses) which represents the dependent values. From the calibration curve plot, it can observe that there is a direct proportion between the concentration of MbH and the peak high up to 6.5 mmol/L for both cells (1 & 2). This direct proportion can be explained due to an increase in the concentration of the formed product (precipitate particulates) which works to attenuate the incident light and leads to an increase in the peak height. The mechanism of the precipitate particulates to attenuate the incident light is a complex but it might be attributed to many factors such as refraction, internal reflection, abstraction and absorbance. In addition, these precipitate particulates have the ability to diverge the incident light when the beam of light hit the particles. Above that, concentration

of MbH (6.5 mmol/L) will cause to make the signal of the energy transducer become independent on the concentration. This behavior can be attributed to that the precipitate particulates start to aggregate and grow up to be in large size which allows creating internal spatial distance between them. These internal distances allow transmitting the light through it towards the detector. The linear regression model is the excellent statistical method to express the relationship between the concentration of an analyte (MbH) and the instrument signal in the calibration curve. From this model, the dynamic, working and linear ranges have been determined as follows: for cell 1, the dynamic range is found to be (0.1-10 mmol/L), the working range is (1.0-7.0 mmol/L) and the linear dynamic range is (1.0-6.5 mmol/L) with $r = 0.9980$, $r^2 = 0.9962$ and $\%R^2 = 99.62$ as shown in Fig.12 A. While the cell 2, the dynamic range is (0.1-10 mmol/L), the working range is (0.7-7.0 mmol/L) and the linear dynamic range is (0.7-6.5 mmol/L) with $r = 0.9986$, $r^2 = 0.9974$ and $\%R^2 = 99.74$ as shown in Fig.12 B. The linearity of the calibration curve is usually expressed through the coefficient of correlation, r , or the coefficient of determination, r^2 . If the value of the coefficient of correlation close to unity ($r = 1$) this is strong evidence that the calibration curve is linear. Table 1 describes the summary of linear regression lines.

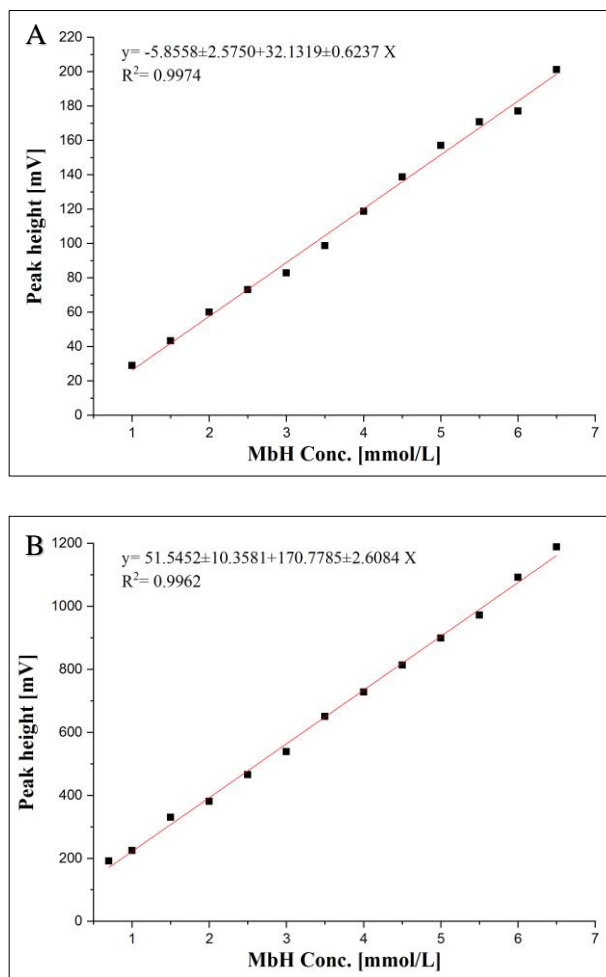

Figure 12. The linear calibration curve for determination of MbH for measuring cell 1 (A) and cell 2(B).

Table 1. The summary of linear regression of the proposed method

Parameter	Obtained Value Proposed method (cell 1)	Proposed method (cell 2)
Linearity (mmol/L)	1.0-6.5	0.7-6.5
Regression equation	$-5.8558 \pm 2.5750 + 32.1319 \pm 0.6237$ [MbH](mmol/L)	$51.5452 \pm 10.3581 + 170.7785 \pm 2.6084$ [MbH] (mmol/L)
Slope	32.1319	170.7785
Intercept	-5.8558	51.5452
Correlation coefficient, r	0.9980	0.9986
Coefficient of determination, R^2	0.9974	0.9962
LOD (mmol/L)	0.28	0.20

Note: All the experiments were conducted at room temperature

The limit of detection (LOD): There are several approaches for calculating the limit of detection such as visual evaluation, Signal-to-Noise approach and Standard Deviation of the Response and the slope. However, in the proposed method there is no noise in the signal therefore, only two approaches will be applied for determining the LOD which are

visual evaluation and Standard Deviation of the Response and the slope as shown in Table 1. For determining the LOD, it can be calculated based on the following equation:

$$\text{LOD} = 3.3 S_a / b \quad (1)$$

Where: S_a = the standard deviation (SD) of the Y-intercept and b = the slope which can be estimated

from the calibration curve. Note that, the S_a is usually meant (RMSE) the root mean squared error or SD of the residuals which can be taken from the regression line.

Specificity: Based on the official guideline of the ICH Q2 in method validation, the specificity can be defined as "Specificity is the ability to assess unequivocally the analyte in the presence of components which may be expected to be present". The effect of interference of excipients on the analysis of MbH in the tablets dosage was carried out by the analysis of sample prepared with all potential excipients present in the tablets (a mixture of excipients) such as Lactose monohydrate, Cellulose, Sodium Starch Glycolate and Magnesium

Stearate but without the MbH. The response of the instrument Y_{zi} (mV) did not show any potential interference of the tablet's excipients.

Precision and accuracy: For the proposed method, relative standard deviation values (RSD) of the inter-day and intra-day have been used for expressing the precision. RSD % of the obtained data have found to be less than 0.8 % for both inter and intraday precision. While a recovery percentage (Rec %) and error % have been used for expressing the accuracy of the obtained results from the proposed method. Rec % of the results have ranged from 99.22-101.13 and 99.39-101.17 for cell 1 & 2 respectively as shown in Tables 2 and 3.

Table 2. The inter- and intra-day assay of precision of the proposed method for the determination of MbH

Expected [MbH] mmol/L	Intra-day (n=5)		RSD%	\bar{Y}_{zi} (mV) (n=3)	RSD%		
	Cell 1	Cell 2					
	Peak height (mV)						
3.5	98.5867±0.8714		0.3708	97.9562±0.2353	0.4683		
	649.8333±1.9965		0.1244	650.5232±0.1182	0.2319		
5.5	169.3833±0.7986		0.2410	170.7066±0.2157	0.2827		
	971.5000±2.2864		0.1654	972.0976±0.1947	0.2645		
Expected [MbH] mmol/L	Inter-day (n=3)		RSD%	Day two (n=3)		Day three (n=3)	
	Day one (n=3)	Day		Measured mmol/L	RSD	Measured mmol/L	RSD
	Measured (n=3)	mmol/L		(n=3)	%	(n=3)	%
3.5	98.9664±0.0756		0.1524	97.8666±0.1677	0.3398	97.8439±0.1937	0.3929
	970.9666±0.0594		0.1164	971.5508±0.0895	0.1753	970.8627±0.0735	0.1440
5.5	97.9812±0.3550		0.4613	98.6678±0.1760	0.3398	99.2708±0.5996	0.7974
	972.2384±0.1471		0.2005	971.6075±0.1124	0.1528	970.6668±0.0424	0.0576

Table 3. The assay of the accuracy of the proposed method for determination of MbH

Nominal concentration of [MbH] (mmol/L)	Peak height (mV) (n=3)	RSD%	ER % ^a	Rec % ^b
	Cell 1 Cell 2			
3.0	85.9664±0.0756	0.1524	-4.746	99.22
	550.5432±0.05948	0.1164	-2.063	99.39
4.0	123.9812±0.3550	0.4613	1.0625	101.13
	729.5384±0.1471	0.2005	-0.828	99.17
Mean			1.7192	98.17
			2.1859	98.28

a The calculated accuracy as error percentage

b The calculated accuracy as recovery percentage

Tablet properties: The majority of the manufactures of generic tablets focus on optimizing the compositions of the tablets by improving the types of excipients mixture to format product that meets the standard requirements. These standards

require materials with high compressibility and flow ability. However, the problem is when a large amount of active pharmaceutical ingredients are mixed with excipients mixture that have poor compressional properties. These excipients may

affect the solubility of the active ingredient, therefore, in order to test it, the physicochemical properties of the tablets must be evaluated prior to any dissolution studies according to the USA pharmacopoeia requirements. The physicochemical properties of the tablets were examined in the proposed method which are: variability, content uniformity and average weight. The friability test evaluates the resistance of tablets to friction and

according to the USA pharmacopoeia, the tablets should have a maximum friability of 1.5%. Moreover, an excellent degree of the content uniformity for the tablet formulations was achieved and did not exceed the standard value (6%). Finally, the average of the tablets must exceed $\pm 5\%$. The obtained results are shown in Table 4 and reported all the tablets are within the required properties of the tablets.

Table 4. Physicochemical properties of the studied tablets

Tablet dosage form (mg)	Friability (%) (n=20)	Average weight (mg) (n=20) Weight variation	Content uniformity (%), (n=10)		
			Lower	Higher	RSD %
135 France	0.02	402.705(385.20-421.53)	98.52	99.65	0.27
135 Egypt	0.03	307.32(292.70-322.10)	94.32	101.66	0.36
135 Syria	0.03	366.81(355.60-380.50)	97.55	102.25	0.45
Official limits	Max. 1.5%	$\pm 5\%$	85-115 %		$\leq 6\%$

UV-spectrophotometry (Reference method) ⁴³:

Spectrophotometric measurements were made in a UV-Vis spectrophotometer type double-beam (Shimadzu, model 1601) with 1.00 cm quartz cell. The absorption spectra, in the UV region, of the MbH is shown in Fig 13. The maximum absorbance of the MbH occurs at 262 nm and it was chosen to be the maximum wavelength and used in the further experiments. In order to estimate the dynamic, working and linear ranges, a series of MbH concentrations was prepared using a distilled water in the range of (0.03-0.6 mmol/L). By conducting the statistical calculation, the drug has shown a linear range (0.12-0.5 mmol/L) with $r=0.9945$, $r^2=0.9892$, LOQ= 0.1432 mmol/L (66.7312 μ g), LOD= 0.0442 mmol/L (20.5972 μ g) at n=12 (n= number of measurements).

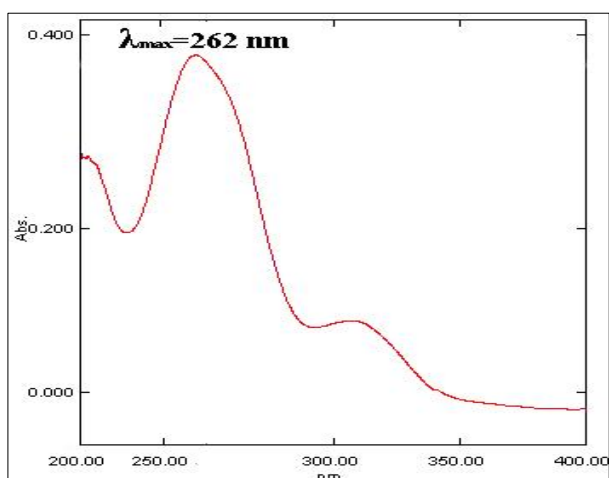

Figure 13. The absorption spectra of MbH

Results and Discussion:

The proposed method for the determination of MbH was optimized by using different aqueous salts, varying of PMA reagent concentrations, flow rates, light intensities, mixing coils, purge time and sample volumes. The optimized method consists of line no 1 which is the carrier stream (distilled water), line no 2 which is the PMA reagent 15 mmol/L, flow rates (2.80 & 3.30 ml/min) for stream-line and reagent line respectively, light intensity (I=1, 5) for cell 1 and 2 respectively, open valve mode for the purge time and 200 μ L as a sample volume. Using all the above-optimized parameters, the reagent PMA is reacted with the MbH forming a yellow precipitate at the Y-junction point, after that the formed precipitate is transferred by the streamline to the NAG Dual & Solo (0-180 $^\circ$) analyser for the detection.

Application of the optimized proposed methods for the determination of MbH in real pharmaceutical samples:

The proposed method was successfully applied to the determination of MbH in commercial tablets of three different companies (Colofac $^\circledR$ (Abbott, France), Colospasmin $^\circledR$ (EIPICO, Egypt) and Duspalina $^\circledR$ (Asia, Syria)) which comprise (135 mg of MbH). The standard addition method was followed to conducting the recovery experiment by adding a known amount of standard MbH to the commercial tablet solution. The obtained results from the recovery of MbH are satisfactory and in excellent agreement with the label claims as shown in Tables 5 & 6. The one-sample t-test and F-test were carried out for the obtained results. Based on the obtained

results of the means of three companies, some of $t_{cal} > t_{tab}$ (t-calculated is bigger than t-tabulated) at were 95% confidence interval and 19 as a degree of freedom. The t-test analysis has shown that there is a significant difference found between the results obtained by three methods and the label claims for

the same batch. The values given by the proposed method were also compared with the reference using the F-test. The statistical evaluation (F-test) has shown that there was no significant difference between the methods used as shown in Table 5 and 6.

Table 5. Determination of commercial tablets containing 135 mg MbH using the proposed and reported methods

Pharmaceutical Preparations	Label claimed (mg/tablet)	Found (mean assay % of label claimed \pm SD) (n=3)		
		References methods UV	Proposed method	
			Cell 1	Cell 2
Colofac ® (Abbott, France)	135	102.27 \pm 0.07	100.05 \pm 0.06	102.50 \pm 0.14
Colospasmin ® (EIPICO, Egypt)	135	99.80 \pm 0.11	99.39 \pm 0.36	101.78 \pm 0.28
Duspalina ® (Asia, Syria)	135	100.86 \pm 0.12	100.71 \pm 0.15	99.80 \pm 0.22

Table 6. The recovery results of the proposed method

Method	Pharmaceutical Preparations	Added (mmol/L)	Found (mmol/L)	Rec %
Proposed Method (Cell 1)	Colofac ® (Abbott, France)	2.0	2.05	102.50
		2.5	2.51	100.40
		3.0	2.98	99.33
	Colospasmin ® (EIPICO, Egypt)	2.0	1.99	99.50
		2.5	2.52	100.80
		3.0	3.02	100.66
	Duspalina ® (Asia, Syria)	2.0	1.98	99.00
		2.5	2.52	100.80
		3.0	3.01	103.33
Proposed Method (Cell 2)	Colofac ® (Abbott, France)	2.0	2.04	102.00
		2.5	2.48	99.20
		3.0	3.02	100.66
	Colospasmin ® (EIPICO, Egypt)	2.0	2.01	100.50
		2.5	2.51	100.4
		3.0	3.06	102.00
	Duspalina ® (Asia, Syria)	2.0	1.99	99.50
		2.5	2.48	99.20
		3.0	3.02	100.66

Comparison of the results obtained by the proposed method and the reference method: In order to conduct a full comparison between the proposed method and the reference method (UV-spectrophotometry), 11 standard solutions of MbH with various concentrations were prepared and analysed using the two methods. Each one of the two methods has shown a linear correlation over a specific range of the analysed concentrations. The obtained fitted curves obtained from the methods can be expressed by the following equations:

$$Y_{cell\ 1} = -5.8558 \pm 2.5750 + 32.1319 \pm 0.6237 [MbH](mmol/L), (n= 11, r= 0.9980)$$

$$Y_{cell\ 2} = 51.5452 \pm 10.3581 + 170.7785 \pm 2.6084 [MbH] (mmol/L), (n= 11, r= 0.9986)$$

$$Y_{UV} = 0.5411 \pm 0.02946 + 2.5322 \pm 0.0935 [MbH] (mmol/L), (n= 11, r= 0.9945)$$

Where Y is the assay values from the three methods. By the examination of the three equations, it was found that the differences observed between the proposed method and the reference method procedures result only from the variability of measurements. Also, the comparison between the three methods has also been achieved statistically by conducting one-way ANOVA test. This test provides information about whether there is an overall significant difference between the methods or it does not depend on the p-value. If the P-value (Sig) is equal or less to 0.05, this means there is a significant difference between the four methods. On the other hand, if the P-value is bigger than 0.05, this means there is no difference between the methods. By conducting the ANOVA test using SPSS software, from the obtained data it can

observed that, all the P-values (sig) from three different drugs companies have shown P-values bigger than 0.05, which means the overall

significant difference between the methods did not occur as shown in Table 7.

Table 7. The statistical analysis of the pharmaceutical preparations

Type of MbH	One sample T-Test $\mu=0.135$ (claim value)				F test				One -way ANOVA (P value at 95%)	
	Cell 1		Cell 2		Cell 1		Cell 2		P_{cat}	P_{tab}
	t_{cal}	t_{tab}	t_{cal}	t_{tab}	F_{cal}	F_{tab}	F_{cal}	F_{tab}		
Colofac ® (Abbott, France)	0.080<2.09		3.762>2.09		Cell 1 VS. UV 2.16>1.10		Cell 2 VS. UV 2.16>1.08		0.995>0.05	
Colospasmin ® (EIPICO, Egypt)	1.028<2.09		2.122>2.09		Cell 1 VS. UV 2.16<1.03		Cell 2 VS. UV 2.16<1.08		0.986>0.05	
Duspalina ® (Asia, Syria)	1.604<2.09		0.460<2.09		Cell 1 VS. UV 2.16<1.11		Cell 2 VS. UV 2.168<1.00		0.996>0.05	

The values of tabulated values of t and F at $P=0.05$ are (2.093) and (2.168) respectively ⁴⁴

Conclusion:

The proposed method (cell 1 and 2) procedure is shown to be sensitive and reproducible in the analysis of MbH in the pharmaceutical preparations. The proposed procedure has been validated according to The International Council for Harmonisation of Technical Requirements for Pharmaceuticals for Human Use (ICH guidelines). In addition to the advantage of the used proposed procedure, the method avoids interference from the existence of any degradation products of drugs. At the same time, the analytical results from the proposed method confirm that the method offers precision, short-time analysis, and accuracy with the added advantages of the speed, simplicity and low cost. Therefore, the proposed method is likely to be very suitable for the analysis of MbH.

Acknowledgements:

The authors are grateful to Prof Dr Issam M. A. Shakir for granting permission to use his analyser (NAG 0-180°) for the project and his help for typing the manuscript.

Authors' declaration:

- Conflicts of Interest: None.
- We hereby confirm that all the Figures and Tables in the manuscript are mine ours. Besides, the Figures and images, which are not mine ours, have been given the permission for re-publication attached with the manuscript.
- Ethical Clearance: The project was approved by the local ethical committee in University of Baghdad.

Authors' contributions statement:

The authors confirm contribution to the paper as follows: study conception, and design: Nagham S. Turkey. Acquisition of data, interpretation, drafting the MS, revision and proofreading: Jalal N. Jeber.

References:

1. Sweetman SC. Martindale: The Complete Drug Reference. Drug Monographs. London: Pharmaceutical press; 2011.
2. Chakraborty DS, Hazra A, Sil A, Pain S. Will controlled release mebeverine be able to surpass placebo in treatment of diarrhoea predominant irritable bowel syndrome. J Family Med Prim Care. 2019;8(10):3173-8.
3. Ivashkin VT, Yu AS, Ye KB, Ye AB, Beniashvili AG, Vasilyev SV, et al. Diagnosis and treatment of the irritable bowel syndrome: clinical guidelines of the Russian gastroenterological association and Russian association of coloproctology. J Gastroenterol Hepatol. 2018;27(5):76-93.
4. Abdulhady SS, Ibrahim KMH. Preparation and evaluation of mebeverine hydrochloride as mucoadhesive buccal tablet for local anesthesia. Trop J Pharm Res. 2017;16(8):1805.
5. Maev IV, Kucheravy YA, Tsukanov VV, Eremnia EY, Andreev DN, Abdulhakov SR, et al. Effectiveness of mebeverine in patients with post-cholecystectomy gastrointestinal spasm: results of prospective observational program "odyssey". TERAPEVT ARKH. 2018;90(8):40-7.
6. El Nabarawi MA, Teaima MH, Abd El-Monem RA, El Nabarawy NA, Gaber DA. Formulation, release characteristics, and bioavailability study of gastroretentive floating matrix tablet and floating raft

- system of Mebeverine HCl. *Drug Des Devel Ther.* 2017;11:1081-93.
7. Aronson JKMADMFHH. Mebeverine. Sixteenth Edition ed: Elsevier B.V; 2016. p. 779.
 8. Cartwright AC. The British pharmacopoeia, 1864 to 2014: medicines, international standards and the state: Routledge; 2016.
 9. Ibrahim H, Issa YM, Abu-Shawish HM. Improving the detection limits of antispasmodic drugs electrodes by using modified membrane sensors with inner solid contact. *J Pharm Biomed Anal.* 2007;44(1):8-15.
 10. Derayea SMS. An application of eosin Y for the selective spectrophotometric and spectrofluorimetric determination of mebeverine hydrochloride. *Anal Methods.* 2014;6(7):2270-5.
 11. Walash M, El-Din MS, El-Enany N, Eid M, Shalan S. First derivative synchronous fluorescence spectroscopy for the simultaneous determination of sulpiride and mebeverine hydrochloride in their combined tablets and application to real human plasma. *J. Fluoresc.* 2010;20(6):1275-85.
 12. Mahdi A, Abas Z. Spectrophotometric Determination of Mebeverine hydrochloride in pharmaceutical preparation via Ion Association Reaction. *JPhCS.* 2018;1032(1):012064.
 13. Lotfy HM, Fayez YM, Michael AM, Nessim CK. Simultaneous determination of mebeverine hydrochloride and chlordiazepoxide in their binary mixture using novel univariate spectrophotometric methods via different manipulation pathways. *Spectrochim Acta A Mol Biomol Spectrosc.* 2016;155:11-20.
 14. Elmasry MS, Elazazy MS, Hassan WS. Utilization of Ion-Associate Formation in Spectroscopic and Conductometric Determination of Mebeverine Hydrochloride in Pharmaceutical Formulations. *Int J Electrochem Sci.* 2013;8:3888-901.
 15. Othman AA, Bagary RI, Elkady EF, El-Kerdawy MM. Development and Validation of Spectrophotometric Methods for Simultaneous Determination of Mebeverine Hydrochloride and Chlordiazepoxide In Bulk and In Dosage Form. *Pharm Anal Acta.* 2006;7(8).
 16. Siddappa K, Mallikarjun M, Reddy T, Tambe M. Simple and sensitive extractive spectrophotometric method for the assay of Mebeverine Hydrochloride in pure and pharmaceutical formulations. *J Chin Chem Soc.* 2008;55(5):1062-8.
 17. Aa O, Ri EB. Development and Validation of Spectrophotometric Methods for the Simultaneous Determination of Mebeverine Hydrochloride and Chlordiazepoxide in Bulk and in Dosage Form. *Pharm Anal Acta.* 2016;7(7).
 18. Parag SM, Senthilkumar GP. Method Development and Validation of Mebeverine HCl in Bulk Drugs by Using Spectrophotometric Method. *RJPT.* 2016;9(9):1407.
 19. Jeber Jalal N, Hassan Raed F, Hammood Mohammad K. Solid Phase Extraction of Theophylline in Aqueous Solutions by Modified Magnetic Iron Oxide Nanoparticles as an Extractor Material and Spectrophotometry Technique for the Determination. *Res J Chem Environ.* 2019;1(23): 94-100
 20. El Walily AFM, El Gindy A, Bedair MF. Application of first-derivative UV-spectrophotometry, TLC-densitometry and liquid chromatography for the simultaneous determination of mebeverine hydrochloride and sulpiride. *J Pharm Biomed.* 1999;21(3):535-48.
 21. Panda SS, Ravi Kumar Bera VV, Sahoo P, Sahu B. Quantitative estimation of mebeverine hydrochloride in sustained-release dosage form using an analytical lifecycle management oriented stability-indicating LC method. *J LIQ Chromatogr R T.* 2018;41(10):637-44.
 22. Nezhadali A, Bonakdar GA. Multivariate optimization of mebeverine analysis using molecularly imprinted polymer electrochemical sensor based on silver nanoparticles. *J Food Drug Anal.* 2019;27(1):305-14.
 23. Lakshmi MV, Pavani M, Rao GD. Rp-hplc method for determination of mebeverine hydrochloride in dosage forms employing ms compatible buffers. *Indian Drug.* 2020;57(3):69-72.
 24. Kumar KRS, Meyyanathan SN, Gowramma B. Chiral RP-HPLC method for enantiomeric separation of mebeverine hydrochloride in the formulation. *Indo Am J Pharm Res.* 2015;5(8):2756-64.
 25. Syed A, Rasheed SH, Afroz S, Noor SW, Fatima SS, Muzaffar-ur-Rehman MD. Development and Validation of Mebeverine Hydrochloride Assay by RP-HPLC Method. *IJPSN.* 2018;11(5):4239-43.
 26. Elmasry MS, Blagbrough IS, Rowan MG, Saleh HM, Kheir AA, Rogers PJ. Quantitative HPLC analysis of mebeverine, mesalazine, sulphasalazine and dispersible aspirin stored in a Venalink monitored dosage system with co-prescribed medicines. *J Pharm Biomed.* 2011;54(4):646-52.
 27. Haggag RS, Shaalan RA, Belal TS. Validated HPLC determination of the two fixed dose combinations (chlordiazepoxide hydrochloride and mebeverine hydrochloride; carvedilol and hydrochlorothiazide) in their tablets. *J AOAC Int.* 2010;93(4):1192-200.
 28. Radwan MA, Abdine HH, Aboul- Enein HY. A validated chiral HPLC method for the determination of mebeverine HCl enantiomers in pharmaceutical dosage forms and spiked rat plasma. *Biomed Chromatogr.* 2006;20(2):211-6.
 29. Moskaleva NE, Baranov PA, Mesonzhnik NV, Appolonova SA. HPLC-MS/MS method for the simultaneous quantification of desmethylmebeverine acid, mebeverine acid and mebeverine alcohol in human plasma along with its application to a pharmacokinetics study. *J Pharm Biomed.* 2017;138:118-25.

30. Ibrahim H, Issa YM, Abu-Shawish HM. Potentiometric flow injection analysis of mebeverine hydrochloride in serum and urine. *J Pharm Biomed.* 2005;36(5):1053-61.
31. Salama NN, Zaaaza HE, Azab SM, Atty SA, El-Kosy NM, Salem MY. Utility of gold nanoparticles/silica modified electrode for rapid selective determination of mebeverine in micellar medium: comparative discussion and application in human serum. *Ionics.* 2016;22(6):957-66.
32. Hoogewijs G, Massart DL. Development of a standardized analysis strategy for basic drugs, using ion- pair extraction and HPLC. Part 8. Method construction for the determination of mebeverine in tablets and biofluids. *J Chromatogr.* 1986;377:391-8.
33. Naguib IA, Abdelkawy M. Development and validation of stability indicating HPLC and HPTLC methods for determination of sulphuride and mebeverine hydrochloride in combination. *Eur J Med Chem.* 2010;45(9):3719-25.
34. Pinkston JD, Chester TL. Putting Opposites Guidelines for Successful SFC/MS. *Anal Chem.* 1995;67(21):650A-6A.
35. Srinivasan V, Sivaramakrishnan H, Karthikeyan B, Balaji TS, Vijayabaskar S. Stress degradation studies on mebeverine hydrochloride and development of a validated stability indicating UPLC method. *J LIQ Chromatogr R T.* 2011;34(16):1631-44.
36. Jeber, J.N. and Turkey, N.S. An optoelectronic flow-through detectors for active ingredients determination in the pharmaceutical formulations. *Journal of Pharmaceutical and Biomedical Analysis.* 2021; 201, p.114128.
37. Turkey, Nagham S., and Jalal N. Jeber. A flow analysis system integrating an optoelectronic detector for the quantitative determination of active ingredients in pharmaceutical formulations. *Microchemical Journal.* 202; 160 (2021): 105710.
38. University of Tanta Details Findings in Fullerenes (Carbon Nanotubes Modified Electrode for Enhanced Voltammetric Sensing of Mebeverine Hydrochloride in Formulations and Human Serum Samples). *Nanotechnology Weekly.* 2017:397.
39. Hu J, Stein A, Bühlmann P. Rational design of all-solid-state ion-selective electrodes and reference electrodes. *TrAC.* 2016;76:102-14.
40. Jeber JN. Quantitative Determination of Ephedrine Hydrochloride in Pharmaceutical Injections by Highly Sensitive Turbidimetric and Reversed-Phase Combined with UFLC Methods. *Chem Chem Technol.* 2019; 2(13):269-74.
41. Hammood MK, Jeber JN, Muhamad YH. Two Techniques (Spectrophotometric and Turbidimetric) for Determination of Ciprofloxacin HCl in Pharmaceutical Drugs with Comparison between the Techniques. *IJS.* 2016;57(3A):1620-8.
42. Guideline ICHHT. Validation of analytical procedures: text and methodology. Q2 (R1). 2005;1:1-15.
43. Pharmacopoeia B. Her Majesty's Stationery Office. London 1988:A195—A200.
44. Miller J, Miller JC. Statistics and chemometrics for analytical chemistry: Pearson education; 2018.

التحليل بالحقن التدفق الجرياني مع قياس التعكسية للتقدير الكمي لهيدروكلوريد الميفبيرين (MBH) في المستحضرات الصيدلانية

جلال ناصر جبر

نغم شاكر تركي

قسم الكيمياء، كلية العلوم، جامعة بغداد، بغداد، العراق.

الخلاصة:

كان الهدف الرئيسي من هذه الورقة هو تطوير والتحقق من صحة طريقة حقن التدفق، وهي طريقة دقيقة ودقيقة وبسيطة واقتصادية ومنخفضة التكلفة ومحددة لقياس التعكس من أجل التقدير الكمي لهيدروكلوريد الميفبيرين (MBH) في المستحضرات الصيدلانية. تم استخدام محلل NAG Dual & Solo محلي الصنع (0-180 درجة) والذي يحتوي على وحدتي اكتشاف متطابقتين (الخلية 1 و 2) لقياسات التعكس. تم تحسين الطريقة المطورة من خلال اجراء معايريات كيميائية وفيزيائية مختلفة مثل تركيزات الكاشف ومحاليل الأملاح المائية ومعدل التدفق وشدة ضوء المصدر وحجم العينة وملف الخلط ووقت الحقن. كانت معاملات الارتباط للطريقة المطورة (r) 0.9986 و 0.9980 للخلية 1 و 2 على التوالي وأظهرت استجابة خطية ضد التركيز على مدى 1.0 إلى 6.5 و 6.5-0.7 مليمول / لتر للخلية 1 و 2 على التوالي. كان حد الكشف (LOD) للخلية 1 والخلية 2 هو 0.28 و 0.21 مليمول / لتر على التوالي. أظهرت الدقة خلال اليوم وبين لتقديرين تسلسليين 3.5 و 5.5 مليمول / لتر من MBH انحرافاً معيارياً نسبياً قدره 0.46 %، 0.28 %، 0.23 %، 0.26 % و 0.39 %، 0.79 %، 0.14 %، 0.05 % للخلية 1 و 2 على التوالي. تم التعبير عن دقة الطريقة المطورة كنسبة مئوية للاسترداد (Rec%) ونسبة خطأ تتراوح بين 99.22 إلى 101.13 و 99.39 إلى 101.17 للخلية 1 والخلية 2 على التوالي. تم اتباع إرشادات ICH للتحقق من صحة الطريقة. تم تطبيق الطريقة التي تم تطويرها بنجاح لتحديد MbH في المستحضرات النقية والصيدلانية ويمكن استخدام الطريقة بشكل ملائم للتحليل الروتيني في المختبر كطريقة لمراقبة الجودة لأن الطريقة تسمح بالتحديد الكمي لـ 60 عينة / ساعة.

الكلمات المفتاحية: تحليل بالحقن الجرياني، هيدروكلوريد الميفبيرين، المستحضرات الدوائية، تحليل ومراقبة الجودة، التعكسية