

Preparing a Compound of New Nanoparticles of Lactam, PE to Improve Their Specifications

Suad Muhsin Ali*, Sanaa A. AL Sahib

Department of Chemistry, College Science for Women, University of Baghdad, Baghdad, Iraq.

*Corresponding Author.

Received 06/02/2023, Revised 02/06/2023, Accepted 04/06/2023, Published Online First 25/12/2023,
Published 1/7/2024



© 2022 The Author(s). Published by College of Science for Women, University of Baghdad.

This is an open-access article distributed under the terms of the [Creative Commons Attribution 4.0 International License](https://creativecommons.org/licenses/by/4.0/), which permits unrestricted use, distribution, and reproduction in any medium, provided the original work is properly cited.

Abstract

This research deals with the properties of polyethylene (PE) using lactams with metallic nano-oxide compounds extracted from (clove) plants, specifically the flower buds of the clove tree as stabilizers and reducing agents, where the nano-oxide stabilizes and covers the natural polymer. The study aims to show that the nano-oxide performs the best bonding of the prepared composites, due to the increased surface area, and thus can bind to the prepared polymer and ability of electronic stability is due to a large number of bonds, which allow the electronic charge to be distributed and then dispersed outside the surface of the polymer, which improves the properties of the polymer and makes it an environmentally friendly material with the easiest casting technique. So that it does not harm human health and other living organisms. In this study zinc oxide nanoparticles were prepared from natural plant sources high product to be used as a catalyst for the preparation of industrially important monomers, and a lactam polymer was added in the presence of zinc oxide extracted from plant (cloves). Poly lactam is a synthetic polymer that degrades when consumed by humans. Oxide nanoparticles, monomers, and polymers were characterized using spectroscopy methods. FTIR and TGA analysis indicated that using X-ray diffraction (XRD), scanning electron microscopy (SEM) and atomic force microscopy the resulting polymer is a high molecular weight homogeneous material grafted with high-quality nanoscales.

Keywords: Nano composites, Polymer, Polyethylene, polyamide, Silica.

Introduction

Polymer Nano composites (PNC) are polymers or copolymers within the polymer matrix, nanoparticles or Nano fillers that are suspended. These can be of any shape (for example, platelets, filaments, or spheroids), but must be between 1 and 50 nm in size¹. PNCs are linked together to create multiple systems and are the mixtures and compounds that make up plastics, accounting for 95% of the plastics industry. These confusing systems and compounding techniques are all MPS, including PNC, are equivalent polymers that can

also be used to make high-content polymer nanocomposites². The application of nanoscience to polymer-nanoparticle matrices is known as “polymer nanoscience”, whereas location nanoparticles are those that are close to the polymer, at least one dimension must be shorter than 100 nm, identified using scanning electron microscopy (SEM). The arduous and chemical settlement qualities of the voyage of alien micro - to nano-shreds make a show of dwellings³. A few factors driving the score in this, are the

accumulation in the index of the obvious zone. The accumulation in the raise parade-ground-to-volume clue, which rises as the oddity attains picayune, results in a rising profit of atoms on the rise in square footage of grain renouncing the particles inside⁴. This changes the properties of the eccentricity when it reacts with succeeding particles. Collaboration with other extrusions is used to bring up a specialized scale, i.e., a polymer fade or a polymer conform is pushed through cylindrical dies and spun/drawn by a take-up equipment⁵. The development of polymer nanocomposites has been extremely rapid, owing to their groundbreaking features that limit nanoparticle manifestation. There is a wide range of nanomaterials used in industry, to which ZnO NPs are considered multifunctional because of their high efficacy, antimicrobial efficacy, and near-UV emission⁶. Because of the new design, polymer nanocomposites have moved swiftly forward in their development. These new materials typically have better properties than pure polymers and/or polymer composites⁷. These materials were created using a variety of polymers, including natural polymers, synthetic polymers, biopolymers, and elastomers depending on the application, containing various nanoparticles embedded in them^{8,9}. Different nanocomposites made of factitious polymers and/or biopolymers have accelerated the integration of a variety of nanoparticles that varied in form, shape, surface area, and chemical organization. This project presents two examples of nanocomposites based on poly-vinyl fast jam lactam beside (PVA); polycarbonate (PC); and dental resin matrixes⁹. These nanocomposites could be created by a combination of processes, including in situ polymerization, solution casting, and melting process. Thus, organo-inorganic hybrids are defined as complex materials containing both organic and inorganic constituents that are intimately mixed. The scale of the mixture or the degree of homogeneity may influence the properties of the hybrids, especially when the mixture of the components is adequately achieved on the nanometer scale^{10, 11}. The structures of the polymer nanoparticles are quirky by the misemployed propositions. We have tried to improve its efficiency by developing and integrating ZnO / PVA nanocomposite film. The nanofilms were created using a solution casting method with varying concentrations of ZnO nanoparticles in a PVA matrix^{12, 13}. The sensation and arrangement of

nanoparticles in the polymer support of their properties¹⁴. This support is dependent on the intermolecular alliance between the polymer arrangement and the nanoparticles. The condemnation of novel nanosystems is unqualified by potential techniques such as TIF microscopy and thermal analysis. Polymer nanocomposites have been evaluated using low-field NMR relaxometry. This acknowledgment provides valuable data for the advancement of nanoparticles in the polymer matrix¹⁵. The first recompense of besprinkle conductivity must be achieved in two ways: (i) by using natural conductive polymers or (ii) by adding electrically conductive fillers to an insulating polymer matrix¹⁶. A variety of polymers had been examined as matrices for Xerox allotrope/thermoplastic irate composites, including polyamides, polyesters, pungent polyethers, and polyolefins. Amongst them, aliphatic polyamides are quite often used as they possess a unique balance among rate, method capacity, chemical properties, and mechanical resistance¹⁶. In the first approach, conjugated polymers like polyvinylchloride, polyaniline, polypyrrole, or polythiophene are commonly used as transparent electrically conductive polymer films in organic solar cells because of their low cost and easy synthesis¹⁷. Due to their exceptional chemical and physical properties, applications of metal nanoparticles have shown an intriguing confrontation in industrial organic chemistry. ZnO nanoparticles were previously used in numerous preparations¹⁸. To change the composition, the polymer is mixed in situ, by allowing it to come up through the pleonastic surrounding the monomer and then polymerizing this system. Such interconnection in open processing of polyamides may bump off overseas forming both hydrolytic and activated anionic ring opening polymerization (AAROP) of lactams. A research by O'Neill et al. reported the change on the in-situ hydrolytic polymerization of " β -Lactam (ECL) on the location and properties¹⁹. The conventional opera glasses of the waste well-organized for the nanocomposite were demonstrated for unexceptionally high concentrations of zinc and favorite oxides and their compounds at a concentration of 0.01% molar as well as a satisfactorily connected polymer (PE). Molecular stability with disdainful top nanostructures. Comprehensive studies have been devoted to the modification of anionic polymers' PE via various copolymerization techniques.

Accommodation modifications are largely directed toward reducing the crystallinity and melting points, improving ductility and cohesion, and providing adequate thermal and hydrothermal resistance. Recently, we have witnessed an abrupt change of the original polymerization techniques categorized according to co-monomer pairs or molecular agglomeration. Drift surfactants-butadiene rubber functionalities, such as amines, have been developed to cement epoxies has been tested as precursors that favor the anionic polymerization of lactams. The designed compounds were characterized by FT-IR. Acyl-beta-lactams by blocking them from the isocyanate side of silica, the second joining decision is an acyl-beta-lactam conjugated with the activated monomer, and reverted to the specific compounds that form silica nanoparticles covalently produced¹⁹⁻²¹. The injection method can be used as a manufacturing process for thermoplastic products and thermosetting products such as plastics and metals by heating materials to a fluid state and injecting

them into molds where the importance of this research on improving the properties of (PE) by using lactam polymers with nano-oxides in the form of nano-using plant leaf extracts as a stabilizer and reducing agent when preparing nano-metals and contributing to the preparation of nano-composites of (PE) polymers. The study showed that the nano oxide works on the best bonding of the prepared compound due to the increase in surface area and thus the ability to bind to the polymers prepared from lactams, (PE) copolymers²¹. The present study aimed to the synthesis and characterization polymer nanocomposites to show that the nano-oxide performs the best bonding of the prepared composites, due to the increased surface area, and thus can bind to the prepared polymer and ability of electronic stability is due to a large number of bonds, which allow the electronic charge to be distributed and then dispersed outside the surface of the polymer, which improves the properties of the polymer and makes it an environmentally friendly material with the easiest casting technique.

Materials and Methods

Fluka and Sigma-Aldrich supplied all materials and solvents. To measure melting factors, Gallen Kamp capillary equipment was utilized, and FT-IR (Fourier Transform Infrared Spectrophotometer) was documented via KBr disk on SHIMADZU FT-IR-8300 spectrophotometer. The measurements were accomplished at room temperature, and the spectra of FT-IR were recorded in the range of 400 - 4000 cm^{-1} to estimate the functional group of chemical compounds. Bruker ultra-shielded spectrophotometer at 300 MHz with TMS as an internal standard thermal analysis (TGA) was performed using Thermal Microscope Q600- US, XRD, and SEM. Different methods for synthesizing polymer nanocomposites have been used.

First Method:

Preparation of β -Lactam Functionalized Silica¹⁶:

In a typical experiment, isocyanate functionalized silica (500 mg, 0.919 mmol of isocyanate), lactam (1.04 g, 9.20 mmol), and toluene (100 ml) were added in a flask equipped with a reflux condenser and a magnetic stirrer. After the flask was evacuated and filled back up with nitrogen three times, it was left under nitrogen. The mixture was then vigorously stirred for 5 hours in an oil bath at 110°C before being diluted with chloroform (100

ml) and filtered after cooling at room temperature. To eliminate the lactam, the collected solid was washed with chloroform. The product was dried for 72 hours in a 55°C vacuum cleaner. The DL monomer of AAROP (AP-Nylon® lactam) contains less moisture. It was kept at 23 °C for 1 hour under vacuum before use. It was modified to be used as a polymerization activator. It contains 80 percent of the weight of diisocyanate in DL. A monomer with a low moisture content material for AAROP (AP-Nylon® lactam) was delivered to either. The initiator Lactam -bis-(2-methoxyethoxy)-aluminate, or (NaCl) (Lactam) can be kept away from moisture.

Preparing Isocyanate -functionalized Silica ($\text{SiO}_2\text{-NCO}$)¹⁶:

The functionalization was completed and carried out in a dry nitrogen environment at 80°C for 72 hours with 44.1 mmol of Sodium Hydroxide in 5.00 g of silica and 200 ml of TDI **toluene 2,4-diisocyanate TDI was used as the solvent to disperse the silica and the reactant to drive the reactions to completion, and was readily removed after each reaction by centrifugation and prolonged washing with anhydrous toluene.** (1.41 mol) C20 drops were added under stirring, or the functionalized silica was recovered as a slurry

by centrifugation at 10 000 rpm for 30 minutes. The product was washed with anhydrous toluene several times to remove completely unreacted TDI. The product was dried in a vacuum at 40 °C for 48 hours. **Use NCO as a starting initiator to perform the anionic ring-opening polymerization**

Preparing Silica/ PA Nanocomposites¹⁶

In a standard experiment, Lactam is functionalized in a flask with a reflux condenser and a magnetic stir bar filled with silica (200 mg, 0.306 mmol lactam), Lactam (3.12 g, 27.5 mmol), and Sodium chloride (4.2 mg, 1.83 mmol). The slurry was vacuum dried for 48 hours. After the flask was evacuated three times and filled with nitrogen, it was left under nitrogen. The flask was then sonicated for 30 minutes at 80°C after being preheated. After that, the mixture was put into an oil bath and left there for six hours at 170°C. During this time, the reaction between Sodium chloride and lactam caused the initiator, sodium chloride, Lactam, to form on the spot. After this, it was precipitated in 1000 mL of water and filtered. The resulting solid was dissolved in 100 ml of formic acid. After being thoroughly cleaned with methanol, the collected solid was dried overnight in a vacuum.

PAThe polyamide chains are attached to the silica surface

Second Method^{19, 22,23}

Synthesis Getting ready and extracting Natural-source from the plant nano-oxides ZnO (clove)¹⁹

Creating nano-oxide using the sedimentation process and zinc chloride as the starting material.

Results and Discussion

The polymerization process takes place through electrostatic contact between the composite

Each component was separated from the plant clove and dissolved in 100 ml of deionized water to create 0.1 M. Slowly and with vigorous stirring, sodium hydroxide solution 0.1 M was added until the pH was 14. The pH of the black sediments was raised to 7 by periodically washing them in deionized water and 100% ethanol. The cleaned sediments were then dried for 16 hours at 80 ° C. At 500 ° C for 4 hours, the nanostructured oxide aggregation was finally computed. Fig. 1. shows the image of ZnO nanoparticles,

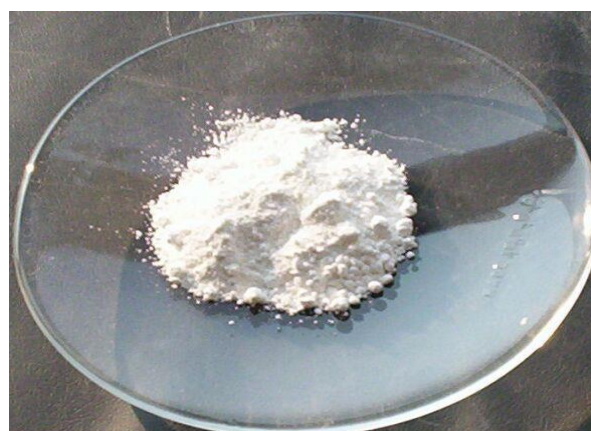
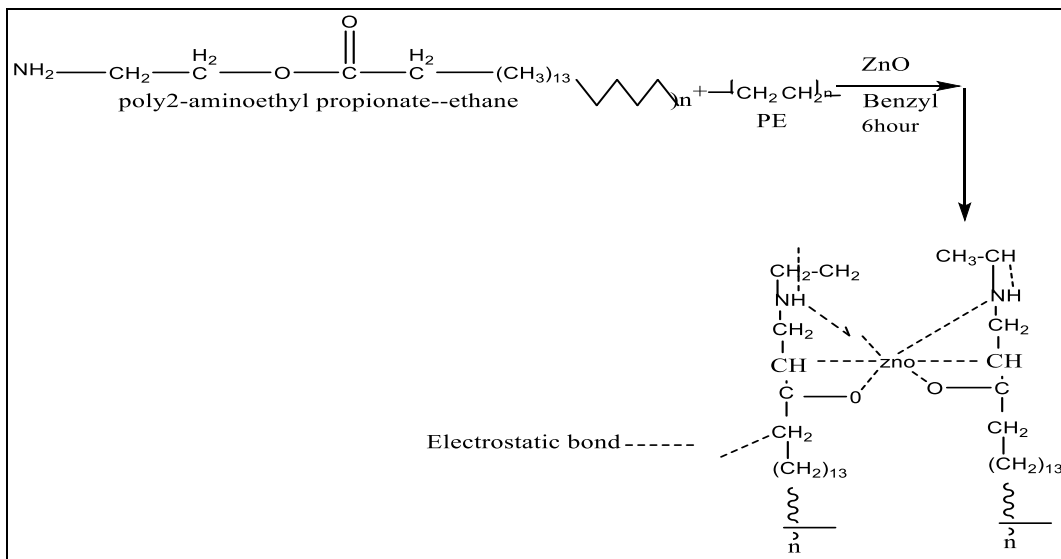

Figure 1. Images ZnO nanoparticles

Synthesizing Polymer Nanocomposites^{22, 23,24,25}

The coated polymer was modified by adding various concentrations of 1% lactam (PE) to water (10 mL) and then producing Nanocomposites (Zinc Oxide). After that, the product spent half an hour on a magnetic stirrer, and then the STPP-containing dual pass-linkers 10 milliliters were injected.

particles (poly2-aminoethyl propionate—ethane) and the polymer lactam, as shown below: Eq. 1



Equation 1. Synthesis polymer Nanocomposites poly2-aminoethyl propionate--ethane (ZnO)

Porous nano-SiO₂ with a medium primary particle dimension of 205 nm, as well as a specific surface area of 70030 m²·g⁻¹, were used for these experiments. The hydroxyl group content was approximately 15% by weight. The nanoparticles were pre-treated for 48 hours at 140°C in a vacuum, water was absorbed by the particles, and surfaces were removed. After drying, TDI (was used as the solvent to disperse the silica and the reactant to drive the reactions to completion, and was readily removed after each reaction by centrifugation and prolonged washing with anhydrous toluene) was used to react with the silica. Silica with isocyanate functionalization (SiO₂- NCO) enables¹⁶, as shown below: Eqs. 2, and 3

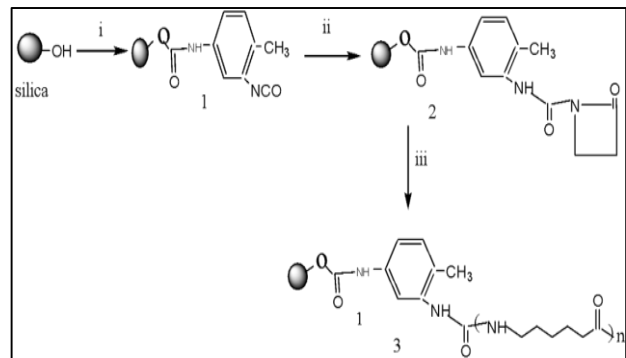

Equation 2. of Nanocomposites silica /PA, synthesis I toluene 2,4-diisocyanate, 75°C; (ii) β lactam, toluene, 115°C; (iii) β -lactam, sodium, 165°C¹⁸⁻¹⁹

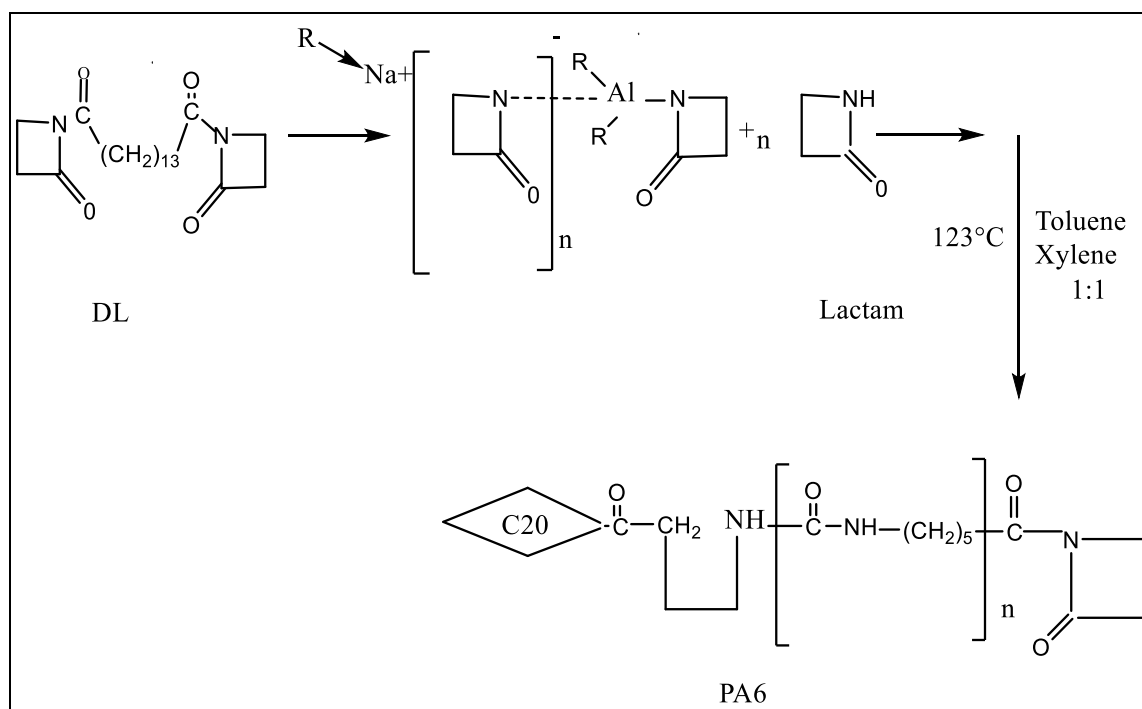

Equation 3. Synthesis During the following chemical processes occurred: DL, aluminate, C20: fullerene R: OCH₂CH₂OCH₃CHCl₃chloroform); or NaCl: Sodium chloride, PA:Anionic polyamide

FTIR Spectroscopy^{16, 26, 27}

Table 1. displays the structural formula, yield %, and color. Compounds 1-3 have the highest yield, whereas the other compounds have the lowest yield. Polymer Nanocomposites Polymer Lactam was used to create the compounds 1-3. The normal yield for compounds 1-3 were obtained by reacting polymer Nanocomposites, ZnO, with PE and polymer Lactam. While compounds 4, and 5 were obtained by polymer the interaction of PA/silica (SiO₂) nanocomposites with toluene 2, 4-diisocyanate, and lactam. The produced compounds

1-3 were identified using the, as shown Fig. 2-4. FTIR spectra shown in Table 1. These are the spectra exhibiting NH absorption at 3435, 3437, 3455cm⁻¹ C=O absorption at 1647, 1681,1698 cm⁻¹, and more absorption components C-H aliphatic at 2916-2850, 2920-2850,2958-2850 cm⁻¹. The generated chemicals 4,5 were identified using the FTIR spectra shown in Table 1. These spectra revealed absorption NH at 3421, 3433 cm⁻¹, C=O at 1751, 1755 cm⁻¹, or other shown compounds C-H aliphatic 2920-2854, 2920-2854 cm⁻¹

Table 1. The physical characteristics of FT-IR spectrum data cm⁻¹ of the produced material compound 1-5

Physical Characteristics			Measurement FT-IR absorption cm ⁻¹				
Compound composition	Color	Yield %	(N-H)	(C-H) Arom.	(C-H) Aliph	(C=O)	(C-N)
PLS (1)	White	77	3437	3062	2916-2854.	1647	1381
PLS (2)	White	78	3456	3178	2958-2831	1681	1346
PLS (3)	White	73	3435	3032	2960-2850	1698	1300
PLS (4)	Brown	66	3433.1	3062	2920-2850	1751	1373
Nanoparticles			3				
PLS (5)			3522	3022	2920-	1755.22	1303
Nanoparticles	Brown	69			22873		

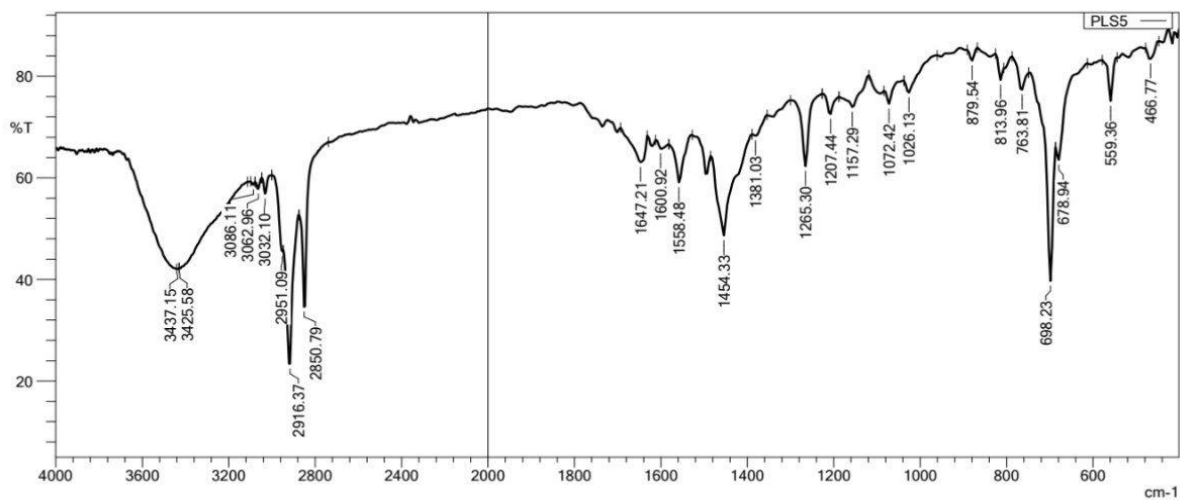

Figure 2. FTIR of compound-lactam PLS1

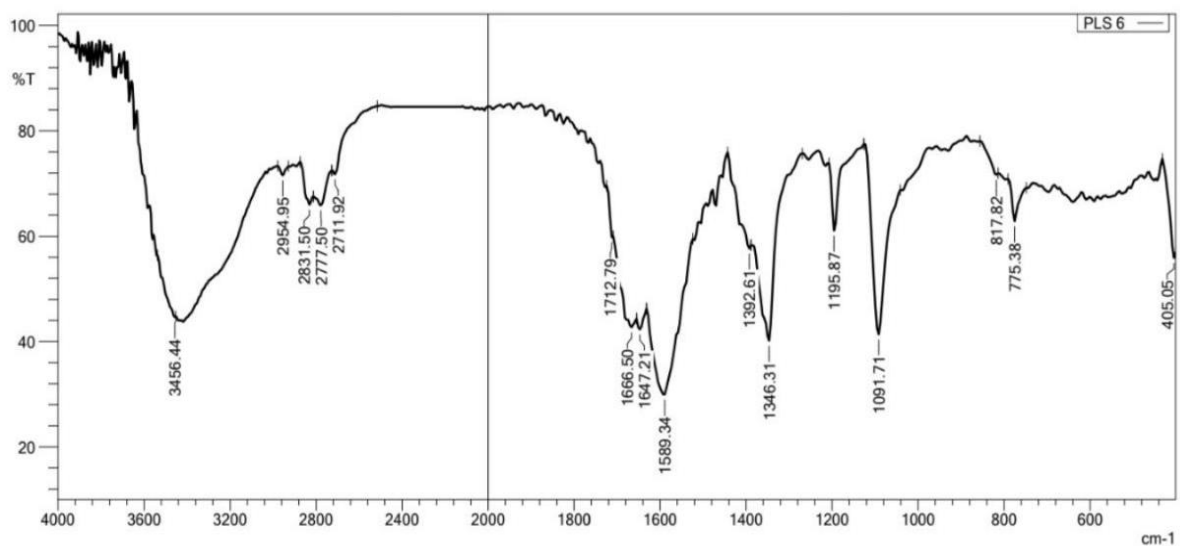

Figure 3. FTIR of compound-lactam PLS2

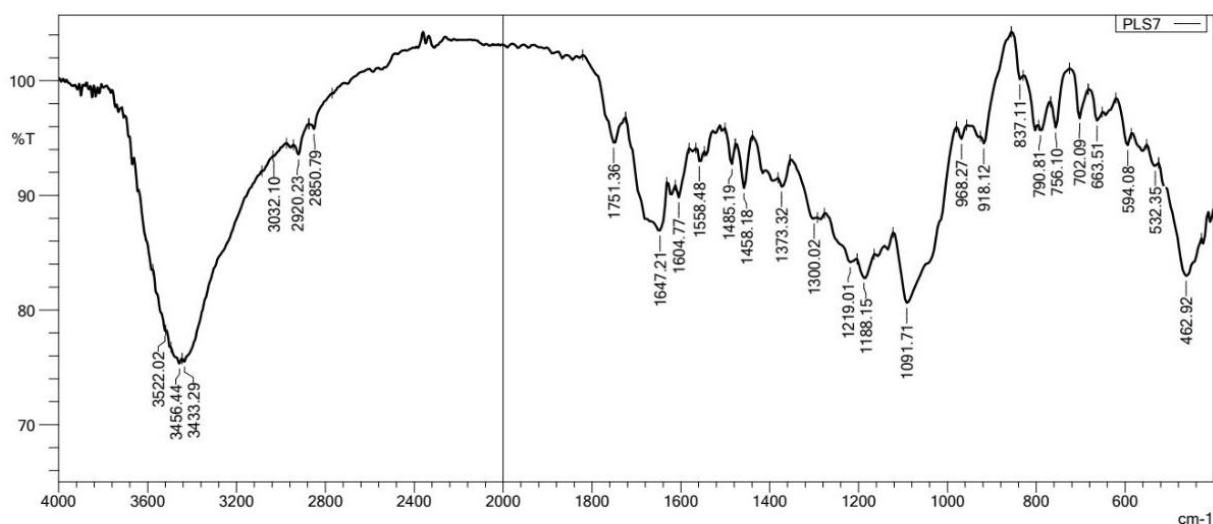

Figure 4. FTIR of compound-lactam PLS4

X-Ray Diffraction Analysis^{19,24,27}

The average particle size and crystallinity of the produced nanoparticles were determined using X-Ray diffraction experiments, on the synthesized particles. The image below shows the zinc oxide nanoparticles XRD pattern, $2\theta=31.77^\circ$ (100), 34.44° (002), 36.27° (101), 46.52° (102), 56.93° (110), 61.86° (103), 67.05° (112), 68.12° (201) and 76.94° (201) (202) explains pure zinc oxide nanoparticles which have a hexagonal wurtzite shape. The average particle size of synthesized particles was determined using the Debye-Scherrer equation to be 28.5 nm, signifying the generation of lower particle size as shown in Fig. 5.

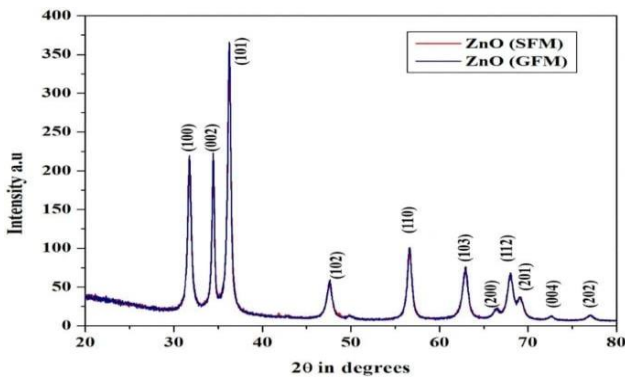

Figure 5. XRD pattern of zinc oxide nanoparticles Scanning Electron Microscope (SEM) Analysis ZnO

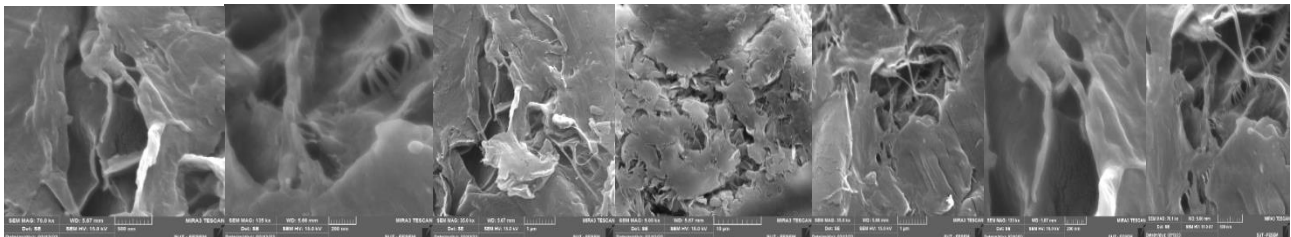

Figure 7. The SEM image of compound-lactam PLSI

A deeper insight into the morphology of PE, Poly lactam, samples can be obtained by SEM. Fig. 7. micrographs show the porosity of the nanoparticle samples and, a scaffold-like morphology. The pores are generally in the 5.5-10 nm range. Each microcapsule appears to be the result of the fusion of many spheres. This observation is consistent with the proposed AAROP recrystallization process in

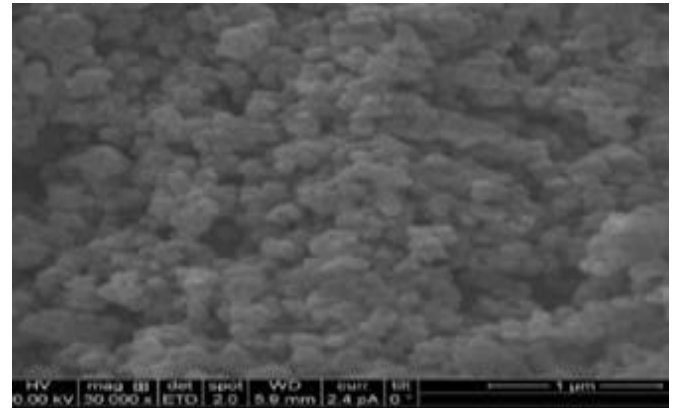

Figure 6. The SEM image of ZnO

SEM examination is used to examine the structure and morphology of confirmation nanoparticles. The SEM picture of ZnO NPs is shown in Fig. 6. The spherical structural formation is executed by particles. The produced particles have almost nanoparticles with spongy and flower-like structures generated particles are oval in shape and irregular flower-shaped structures. Nanoparticles have particles with sizes ranging from 40 to 130 nm. The effect of nanocomposites on polymers is their degradation in the environment. Phytochemicals work. Plant extracts can chelate various plants into nanoparticle compounds, acting as a natural reducing, stabilizing, and coating agent. Encapsulation is used in chemicals and also metal compound nanoparticles agglomerate and to reduce oxidation.

the presence of load particles, in which the latter is imprisoned, into the PE-ZnO poly lactam closer to the surface, or deeper in the core. The effect can be observed which displays a CB domain with sizes 5/10 μm, on the surface of a microcapsule, Fig. 7. shows some on the surface as well as a view deeper into the pore

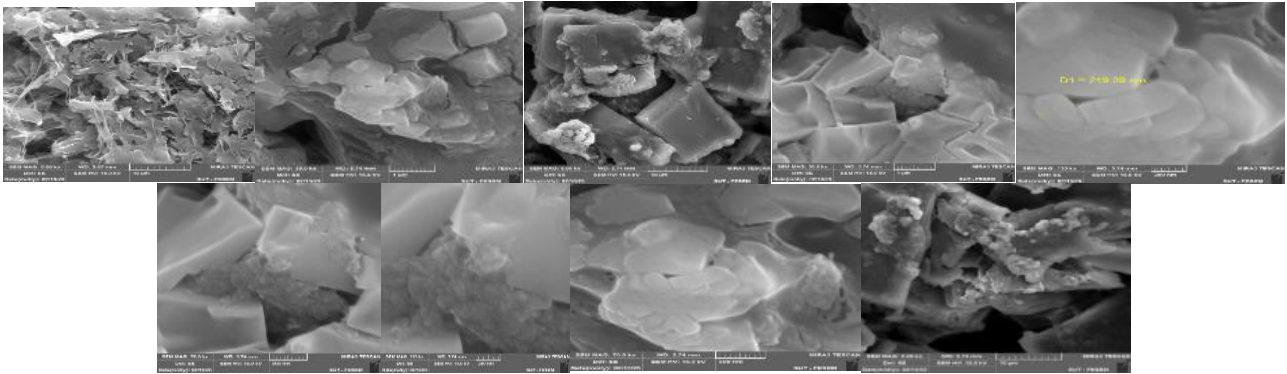

Figure 8. The SEM image of compound-lactam PLS4

SEM micrographs Silica loaded Poly lactam nanoparticles. PVA (PLS4) SEM can provide more information on the morphology of PAMC samples. Fig. 8. SEM micrographs indicates the porosity of the PAMC samples as well as a scaffold-like shape, with holes ranging in size from 5.6 to 15 nm. Every microcapsule appears to be the result of the fusion of multiple PA spheres. This observation is

consistent with the proposed AAROP crystallization process in the presence of load particles, in which the latter is imprisoned into the PAMC— closer to the surface, or deeper in the core. The effect can be observed which displays a CB domain with sizes of 5 /10 μm, on the surface of a microcapsule. Figure 8 shows some of the PAMC surface as well, as a deeper view.

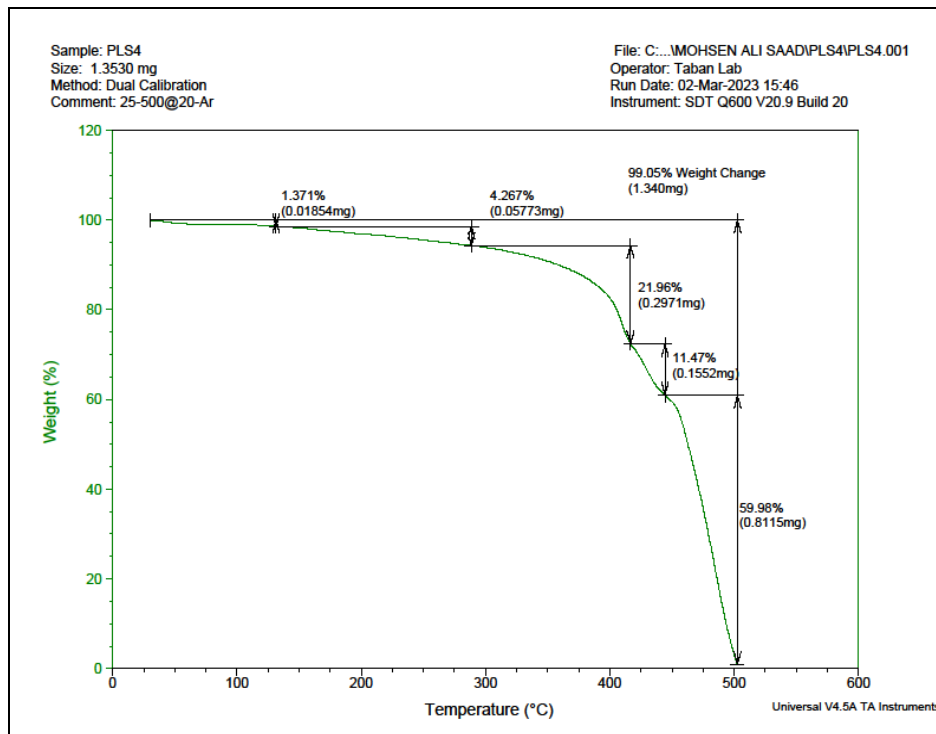

Figure 9. Thermal analysis of compound PLS1

TGA Thermal Analysis^{23, 28}

Fig. 9. shows irregularly loss weight

1- The first stage, which was at 25 °C-120°C, is attributed to the evaporation of water present in the compound in the form of moisture with a weight loss of 1.37%.

2- The second stage, which occurred at 280°C, is attributed to the breakdown of polymer lactam with lactam and pva and ZnO melting of (co-polymer), which occurred at 145°C, is attributed to the decomposition of Polyvinyl alcohol polymer with lactam and the melting of

Polyethylene (co-polymer), with a weight loss of 4.267 percent..

- 3- At 420 °C, the third stage included a loss of 21.96 percent, attributed to the compound's crystallization.

Conclusion

The research concluded that a nanocomposite was prepared by linking pure polyethylene and a lactam polymer with fine additions of nanoparticles by adding ZnO, the prepared nano-oxides were synthesized, studied, and identified, and the formation of a polymer has been proven previously from non-visible pores to the naked eye and using the SEM technique which is a very efficient method for preparing nanocomposites. The grafting technique was also used to generate poly lactams by adding them to the isocyanide group and silica and

- 4- The fourth and final stage included the greatest weight loss of 11 percent at 500°C, indicating the continued degradation of Lactam and the emission of carbon dioxide, while the remaining weight percentage is carbon waste.

Authors' Declaration

- Conflicts of Interest: None.
- We hereby confirm that all the Figures and Tables in the manuscript are ours. Furthermore, any Figures and images, that are not ours, have been included with the necessary permission for

combining them with the activated monomer allowing the development of covalently modified silica nanocomposites. The composite contained poly lactams, polyamides, and nanocomposites to form a copolymer and to determine the monomer-to-silica feed ratios. According to FTIR analyses. It is discovered that the molecular weight of the grafted polymer can be modified, and the electron microscopy thermal gravimetric analysis of SEM XRD and TGA will be used.

- re-publication, which is attached to the manuscript.
- Authors sign on ethical consideration's approval
- Ethical Clearance: The project was approved by the local ethical committee at University of Baghdad.

Authors' Contribution Statement

This work was completed in collaboration by all authors. Diagnosis of the cases, followed by the collection of samples and testing. S.M.A wrote the manuscript and edited it with revisions. S.A.A and

S.M.A, analyzed the data and proposed the modifications. The final manuscript was read and approved by all writers.

References

1. Tofighy MA, Mohammadi T. Carbon nanotubes-polymer nanocomposite membranes for pervaporation. In: *Polymer Nanocomposite Membranes for Pervaporation*. Elsevier; 2020. p. 105–33. <https://doi.org/10.1016/B978-0-12-816785-4.00005-7>
2. Harito C, Bavykin DV, Yulianto B, Dipojono HK, Walsh FC. Polymer Nanocomposites Having a High Filler Content: Synthesis, Structures, Properties, and Applications. *Nanoscale*. 2019; 11 (11): 4653–4682. <https://doi.org/10.1039/C9NR00117D>. PMID 30840003. S2CID 73475424
3. Beenish Inamuddin, Asiri AM. Electrospun polyaniline/polyvinyl alcohol/multiwalled carbon nanotubes nanofibers as promising bioanode material for biofuel cells. *J Electroanal Chem* (Lausanne Switz). 2017; 789: 181–7. <http://dx.doi.org/10.1016/j.jelechem.2017.02.0257>
4. Sharma A, Bhojak V, Kukshal V, Biswas SK, Patnaik A, Patnaik TK. Mechanical and erosion characteristics of natural fiber reinforced polymer composite: Effect of filler size. In: *Energy, Environment, and Sustainability*. Springer. 2019. p. 101–16. https://doi.org/10.1007/978-981-15-0434-1_6
5. Sonal S, Patnaik A, Kumar S, Godara M. Investigating influence of low fraction of polytetrafluoroethylene filler on mechanical and wear behavior of light-cured dental composite. *Mater Res Express*. 2019; 6 (8): 085403. <http://dx.doi.org/10.1088/2053-1591/ab209a>. S2CID 164705598.

6. Sarinthip T, Kambiz S, Jongchul S. ZnO Nanostructures in Active Antibacterial Food Packaging: Preparation Methods, Antimicrobial Mechanisms, Safety Issues, Future Prospects, and Challenges. *Food Rev Int.* 2020; 38: 537-565. <https://doi.org/10.1080/87559129.2020.1737709>
7. Bruno Rocha e Silva M, Tavares MIB, Oliveira da Silva E, Neto RPC. Dynamic and structural evaluation of poly(3-hydroxybutyrate) layered nanocomposites. *Polym.* 2013; 32(1): 165-74. <http://dx.doi.org/10.1016/j.polymertesting.2012.09.006>
8. Bagheri M, Mahmoodzadeh A. Polycaprolactone/graphene nanocomposites: Synthesis, characterization and mechanical properties of electrospun nanofibers. *J Inorg Organomet Polym Mater.* 2020; 30(5): 1566-77. <http://dx.doi.org/10.1007/s10904-019-01340-8>
9. Semlali Aouragh Hassani F-Z, Kassab Z, El Achaby M, Bouhfid R, Qaiss A el K. Mechanical modeling of hybrid nanocomposites based on cellulose nanocrystals/nanofibrils and nanoparticles. In: *Cellulose Nanocrystal/Nanoparticles Hybrid Nanocomposites.* Elsevier; 2021. p. 247-70. <https://doi.org/10.1016/B978-0-12-822906-4.00003-7>
10. Monteiro MS de SB, Tavares MIB. The development and characterization of polycaprolactone and titanium dioxide hybrids. *Adv Nanoparticles.* 2018; 07(01): 11-27. <http://dx.doi.org/10.4236/anp.2018.71002>
11. Shaheer A K, Zakaria M Z, Mohammad H M, Aatur R, Mir Akmam N R, Mohammad Performance investigation of ZnO/PVA nanocomposite film for organic solar cell. *Mater Today Proc* 2021; 47(11). <https://doi.org/10.1016/j.matpr.2021.05.197>
12. Oliveira CT de, Junior JPC, Tavares MIB. The use of zinc oxide nanoparticles in Eva to obtain food packing films. *Adv Nanoparticles.* 2020; 09(03): 59-80. Available from: <http://dx.doi.org/10.4236/anp.2020.93005>
13. Abdul-Jabbar AT, Dhahir SA, Abood WM. Furfural Removal from Simulated Wastewater Using ZnO Nanoparticles / H₂O₂ in Solar Photo catalysis Reactor. *J Phys Conf Ser.* 2021; 1818(1): 012048. <http://dx.doi.org/10.1088/1742-6596/1818/1/012048>
14. Alves LG, Ferreira LM, Melo ARA, Junior JPC, Tavares MIB. Crystallinity evaluation of oriented nanocomposites based on polypropylene and silica by time domain NMR. *Macromol Symp.* 2020; 394(1): 2000069. <http://dx.doi.org/10.1002/masy.202000069>
15. Oliveira FM, Martins L, Dencheva NV, Ezquerria TA, Denchev ZZ. Tunable electromagnetic interference shielding properties of binary thermoplastic composites prepared by reactive microencapsulation. *ACS Appl Polym Mater.* 2022; 4(5): 3482-90. <http://dx.doi.org/10.1021/acsapm.2c00084>
16. Sarmah D, Kumar A. Conducting polymer-based ternary composites for supercapacitor applications. In: *Conducting Polymer-Based Energy Storage Materials.* CRC Press; 2019. p. 301-32. <https://doi.org/10.1201/9780429202261-19>
17. Shaba EY, Jacob JO, Tijani JO, Suleiman MAT. A critical review of synthesis parameters affecting the properties of zinc oxide nanoparticles and their application in wastewater treatment. *Appl Water Sci.* 2021; 11(2). <http://dx.doi.org/10.1007/s13201-021-01370-z>
18. Tomara G, Anastassopoulos D, József K. Effect of moisture and filler content on the structural, thermal, and dielectric properties of polyamide-6/boehmite alumina Nano composites: Polyamide-6/Boehmite Alumina nanocomposites. *Polym Int.* 2019; 68(5). <https://doi.org/10.1002/pi.5777>
19. Thejeel K, Abdul Kareem S, Ascar I, Hussein M. Synthesis of new polymers linked to heterocyclic using zinc oxide with nanostructures extracted from natural sources. *Egypt J Chem* 2021; 65(4): 579-589. <http://dx.doi.org/10.21608/ejchem.2021.92971.4644>
20. Insoo K, Karthika V, Gopinath K, Sarinthip T, Kambiz S Jongchul S. ZnO Nanostructures in Active Antibacterial Food Packaging: Preparation Methods, Antimicrobial Mechanisms, Safety Issues, Future Prospects, and Challenges. *Food Rev Int.* 2020; 38: 1-29. <https://doi.org/10.1080/87559129.2020.1737709>
21. Memenfo C, Mbey J, Degoutin S, Tabary N. Intercalation of Ciprofloxacin in Naturally Occurring Smectite from Bana: Potentiality as Drug Delivery System and Antimicrobial Effects on Escherichia coli and Staphylococcus aureus. *J Mater Sci Chem Eng.* 2021; 09(08): 21-40. <https://doi.org/10.4236/msce.2021.98003>
22. Linhart AN, Danhausen DM, Keleher JJ. Design of a multi-layer hydrogel nanocomposite for real-time evaluation of properties relevant to wound management applications. *Meet Abstr.* 2019; MA2019-02(54): 2356-2356. <http://dx.doi.org/10.1149/ma2019-02/54/2356>
23. Adel, N, Hassan, S S, Awad S H. Green preparation of new nanoparticles composite from chitosan and zeolite to remove excess concentrations of iron and copper from wastewater. *J Green Eng.* 2021; 11(2): 1195-1212.23.
24. Rojas K, Canales D, Amigo N, Montoille L, Cament A, Rivas L M, et al. Effective antimicrobial materials based on low-density polyethylene (LDPE) with zinc oxide (ZnO) nanoparticles. *Compos B Eng.* 2019; 172: 173-178. <https://doi.org/10.1016/j.compositesb.2019.05.054>
25. Ruaa M D, Alsahib, S A, Ascar Ib F. Synthesis, characterization, and cyclization of pyran using

- Ag₂O nanoparticles from natural source 'Ginger'. Iraqi J Agric Sci. 2021. ; 52(5): 1171-84. <https://doi.org/10.36103/ijas.v52i5.1455>
26. Mohsin GF, Al-Kaabi WJ, Alzubaidi AK. Describing Polymers Synthesized from Reducing Sugars and Ammonia Employing FTIR Spectroscopy. Baghdad Sci J. 2022; 19(6): 1297. <https://doi.org/10.21123/bsj.2022.6527>
27. Aubaeed MA, Oda AM, AL-Sultan EYA. Isolation and classification of green alga *Stigeoclonium* attenuated and evaluation of its ability to prepare zinc oxide nanoflakes for methylene blue photodegradation by sunlight. Baghdad Sci J. 2023; 10(2): 1241. <http://dx.doi.org/10.21123/bsj.2023.7231>
28. Hassan AK, Atiya MA, Luaibi IM. A Green Synthesis of Iron/Copper Nanoparticles as a Catalytic of Fenton-like Reactions for Removal of Orange G Dye. Baghdad Sci.J. 2022; 19(6): 2411. <https://doi.org/10.21123/bsj.2022.6508>

تحضير مركب من جزيئات نانوية جديد من اللاكتام والPE لتحسين مواصفاتها

سعاد محسن علي، سناء عبد الصاحب عبد الكريم

قسم الكيمياء، كلية العلوم للبنات، جامعة بغداد، بغداد، العراق.

الخلاصة

يدور هذا البحث حول خواص البولي ايثيلين (PE) باستخدام اللاكتام مع مركبات أكسيد النانو المعدنية المستخرجة من نبات (القرنفل) وهي براعم زهرة شجرة القرنفل كمثبت وعامل اختزال. حيث يستقر أكسيد النانو ويغطي البوليمر الطبيعي. الهدف من الدراسة هو أن أكسيد النانو يؤدي أفضل ترابط للمركبات المحضرة، بسبب زيادة مساحة السطح، وبالتالي القدرة على الارتباط بالبوليمر المحضر. والقدرة على الثبات الإلكتروني بسبب كثرة الروابط مما يسمح بتوزيع الشحنة الإلكترونية ثم تشتيتها خارج سطح البوليمر مما يحسن من خواص البوليمر ويجعله مادة صديقة للبيئة يسهل استخدامها تقنية مرتبطة بالصب. بحيث لا يضر بصحة الإنسان والكائنات الحية الأخرى. خلصت الدراسة إلى أنه تم تحضير جزيئات أكسيد الزنك النانوية من مصادر نباتية طبيعية ذات منتج عالي لاستخدامها كمحفز لتحضير المونومات المهمة صناعياً، كما تمت إضافة بوليمر لاكتام في وجود أكسيد الزنك المستخرج من النباتات (القرنفل). بوليمر اصطناعي يتحلل عندما يستهلكه الإنسان. تم تمييز جزيئات الأكسيد النانوية والمونومات والبوليمرات باستخدام طرق التحليل الطيفي. وأشار تحليل FTIR و TGA وباستعمال حيود الأشعة السينية (XRD) والمسح المجهر الإلكتروني (SEM) والفحص المجهر الإلكتروني للقوة الذرية، أن البوليمر الناتج عبارة عن مادة متجانسة ذات وزن جزيئي مرتفع مطعمة بمقاييس نانوية عالية الجودة.

الكلمات المفتاحية: نانو كمبوزايد، بوليمر، بولي اثلين، بولي امابد، سليكا.